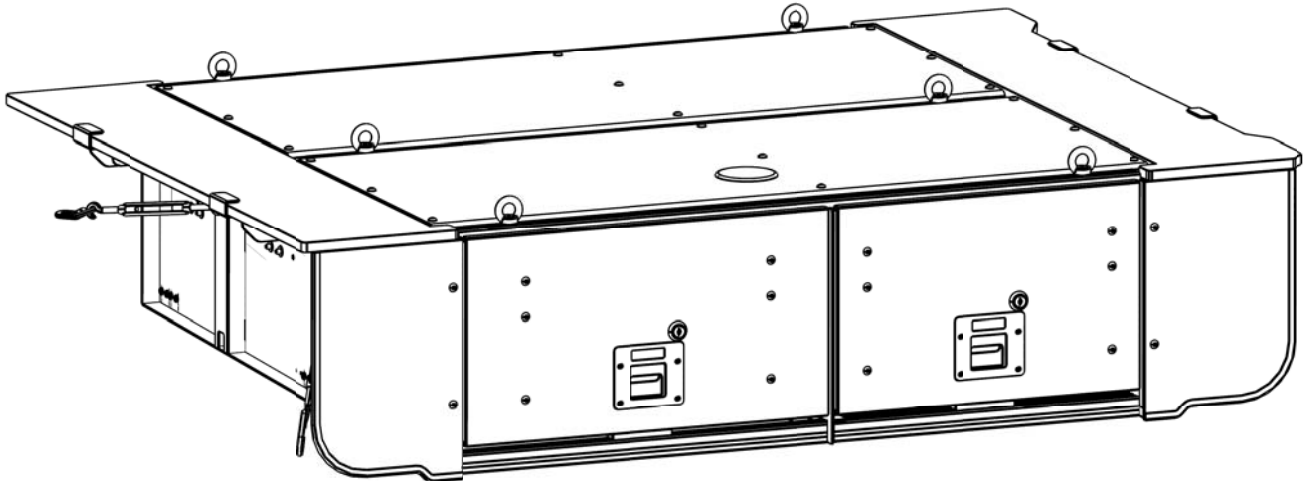

**INSTALL TIME: 45 mins**

Thank you for purchasing a Front Runner Storage System.

This Storage System is made up of the following components:

1. A Drawer System - SSDR002
2. A Drawer Deck Completion Set Brackets - SSWS002
3. A Vehicle Specific Deck Completion Set - SSDS502

Before you start, take a moment to familiarize yourself with these Fitting Instructions and all the components received. Depending on the vehicle not all components received will be used. Refer to Page 2 for a list of all the components and quantities if required.

IMPORTANT WARNING!

IT IS CRITICAL THAT ALL FRONT RUNNER PRODUCTS BE PROPERLY AND SECURELY ASSEMBLED AND ATTACHED TO YOUR VEHICLE. IMPROPER ATTACHMENT COULD RESULT IN AN AUTOMOBILE ACCIDENT, AND COULD CAUSE SERIOUS BODILY INJURY OR DEATH TO YOU OR TO OTHERS. YOU ARE RESPONSIBLE FOR ASSEMBLING AND SECURING ALL FRONT RUNNER PRODUCTS TO YOUR VEHICLE, CHECKING THE ATTACHMENTS PRIOR TO USE, AND PERIODICALLY INSPECTING THE PRODUCTS FOR ADJUSTMENT, WEAR, AND DAMAGE. THEREFORE, YOU MUST READ AND UNDERSTAND ALL OF THE INSTRUCTIONS AND CAUTIONS SUPPLIED WITH YOUR FRONT RUNNER PRODUCT PRIOR TO INSTALLATION OR USE. IF YOU DO NOT UNDERSTAND ALL OF THE INSTRUCTIONS AND CAUTIONS, OR IF YOU HAVE NO MECHANICAL EXPERIENCE AND ARE NOT THOROUGHLY FAMILIAR WITH THE INSTALLATION PROCEDURES, YOU SHOULD HAVE THE PRODUCT INSTALLED BY A PROFESSIONAL INSTALLER OR OTHER QUALIFIED PERSONNEL.

1 GET ORGANIZED...

Here is what you are looking at for SSSDR0002:

Item #	Quantity	Description
1	1	DRAWER SYSTEM
2	4	TURNBUCKLE
3	4	M6 WING NUT
4	6	M6 EYE NUT
5	6	NYLON WASHER
6	4	60mm C-HOOK
7	6	M6 STUD PLATE

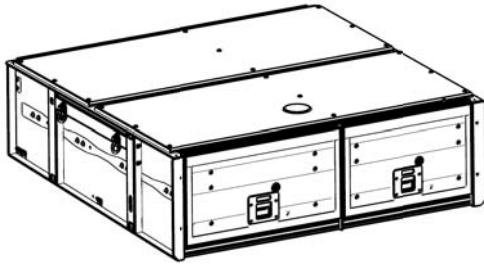

You will need:

- 8 mm & 10 mm Flat or Socket Wrench
- 14 mm Socket Wrench
- 3 mm & 4 mm Hex Key
- a Friend

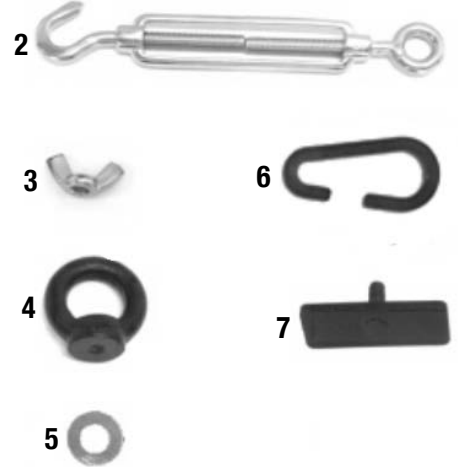

Here is what you are looking at for SSWS002:

Item #	Quantity	Description
8	4	SIDE WING - 1 LEFT, 1 RIGHT
9	4	WING SLIDER - 1 LEFT, 1 RIGHT
10	16	M6 x 16 HEX BOLT
11	16	M6 x 19 FLAT WASHER
12	8	M6 FLAT WASHER
13	8	M6 NYLOC NUT
14	8	M6 SPRING WASHER

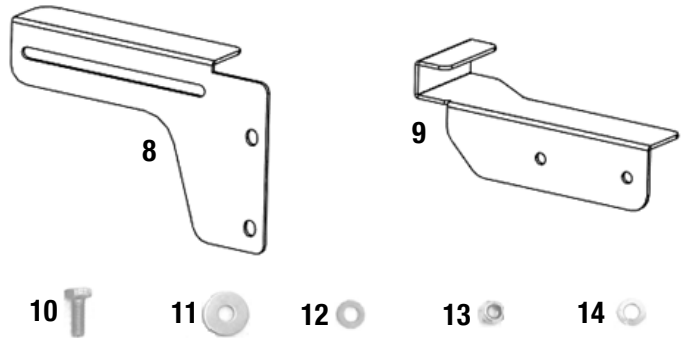

Here is what you are looking at for SSSD502:

Item #	Quantity	Description
15	2	SIDE WING - 1 LEFT, 1 RIGHT
16	2	WING SLIDER - 1 LEFT, 1 RIGHT
17	2	M10 D-RING
18	4	M5 x12 BUTTON HEAD BOLT
19	4	M5 FLAT WASHER
20	4	M5 NYLOC NUT
21	2	37 mm C-HOOK
22	1	HOOK BRACKET
23	2	FRONT FACE - 1 LEFT, 1 RIGHT

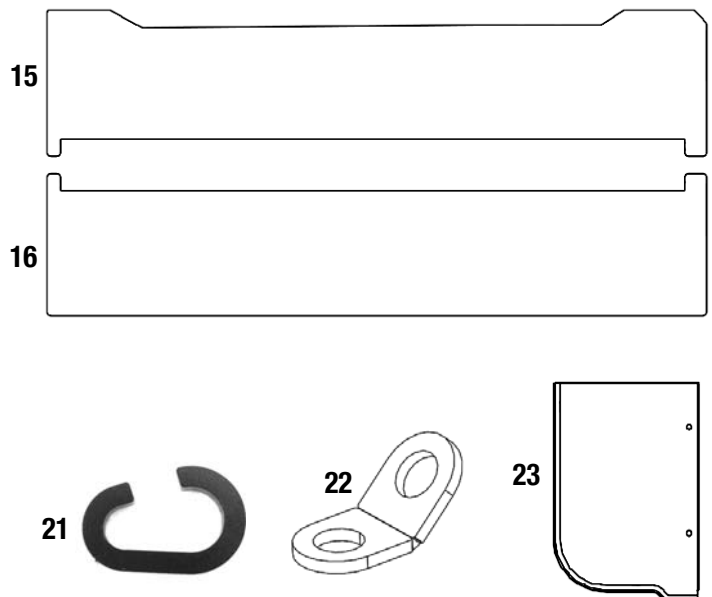

2 PREPARE FOR INSTALLATION

- (A) Loosely assemble the left and right hand Side Wing Sets (Items 8, 9) as shown below using two M6 x 16 Hex Bolts, two M6 Flat Washers, two M6 x 19 Flat Washers and two M6 Nyloc Nuts as shown (Items 10, 11, 12, 13) received with SSWS002.

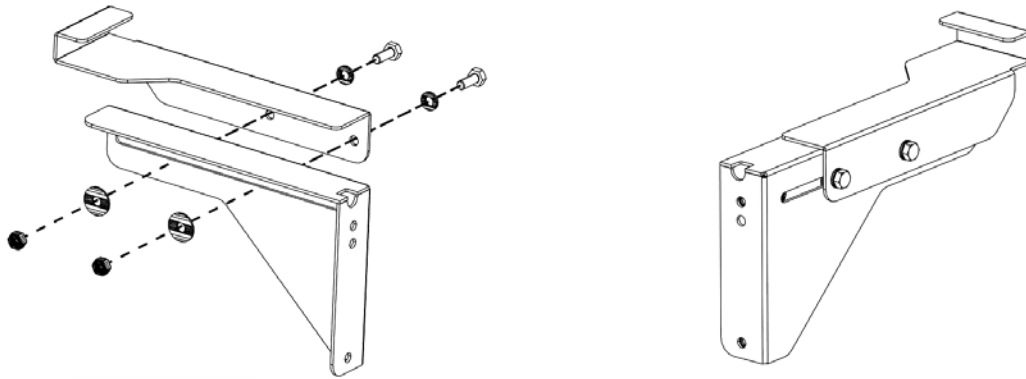

- (B) Loosen the round end of the two Turn Buckles (Item 2) supplied with SDR005 and assemble a M6 Wing Nut (Item 3) as shown. Reassemble the Turn Buckle.

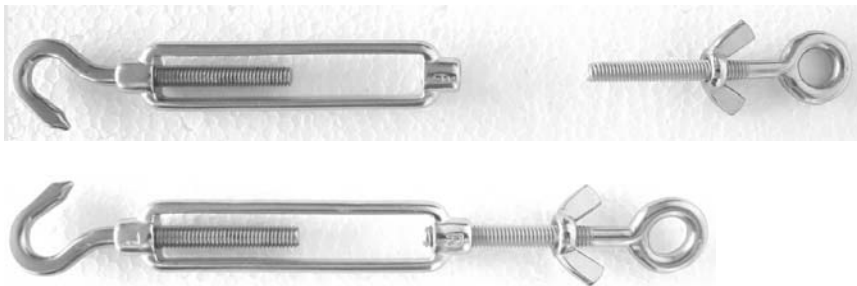

- (C) If your vehicle has the third row of seats fitted, loosen and remove the seats. Keep the bolts in a safe place to be used later.

- (D) Loosen and remove the two seat anchors found in the centre of the vehicles load area.

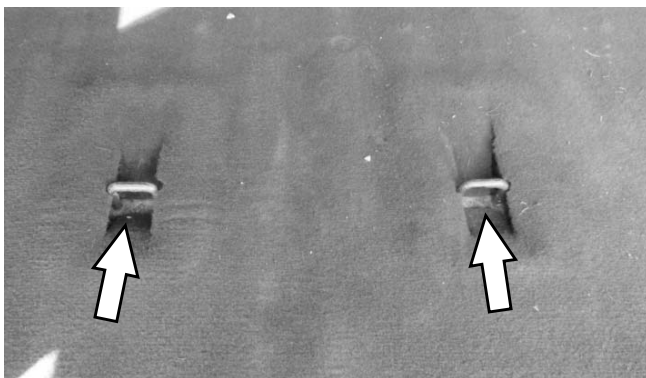

2 PREPARE FOR INSTALLATION CONT...

- (E) Secure a M10 D-ring (Item 17) to each of the seat mounting points as indicated using two of the original mounting bolts from Step 2C. It is suggested that the remaining two bolts get secured back to the other two open mounting points for safe keeping.

Left Hand Side of Vehicle

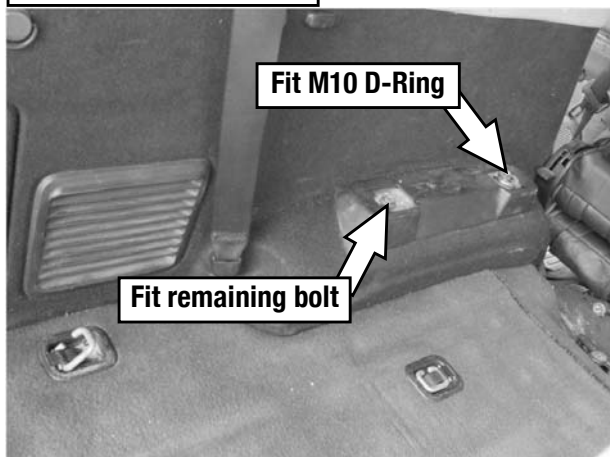

Right Hand Side of Vehicle

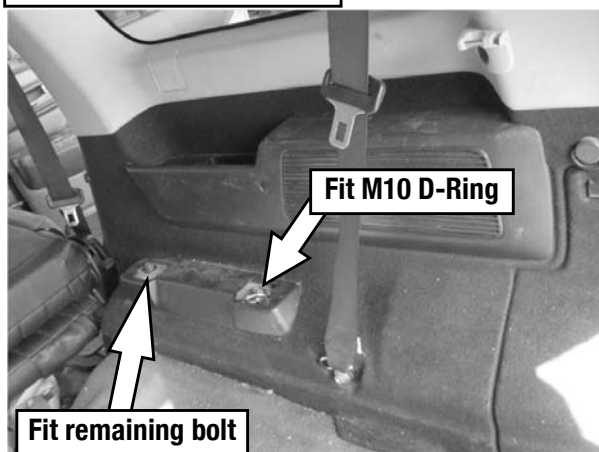

- (F) Loosen the right hand side rear seat belt and secure the Hook Bracket (Item 22) between the vehicles' body and the seat belt as shown.



3 INSTALL DRAWER SYSTEM

- (B) Place the Drawer (Item 1) into the vehicle, lining up the front of the Drawer with the edge of the plastic trim as shown below. Center the Drawer left to right.



- (C) Secure the right hand side of the Drawer System to the vehicle using the Turnbuckles and C-Hooks (Items 2, 6, 21) as shown below. Ensure the Drawer System remains in position while tightening the Turnbuckles.

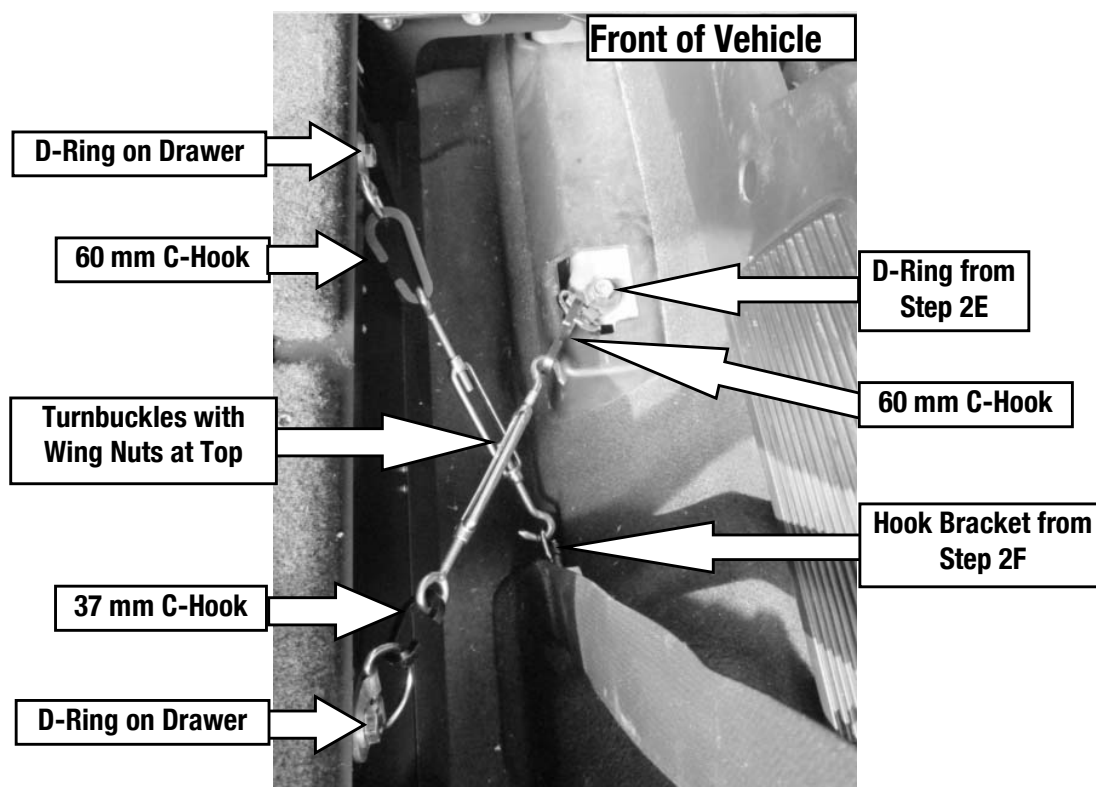

3

INSTALL DRAWER SYSTEM CONT...

(D) Secure the left hand side of the Drawer System to the vehicle using the Turnbuckles and C-Hooks (Items 2, 6, 21) as shown below. Ensure the Drawer System remains in position while tightening the Turnbuckles.

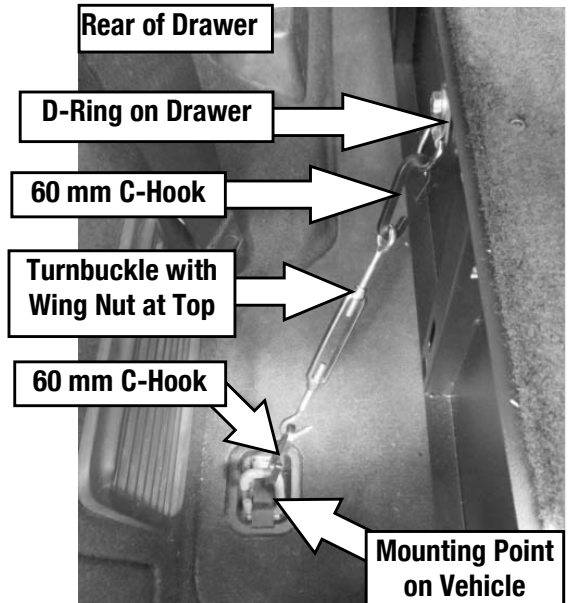
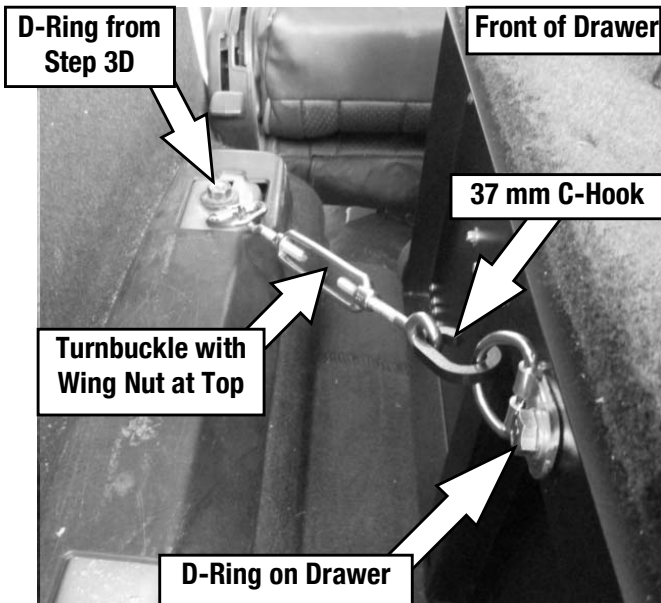

(E) Secure the adjustable Wing assemblies from Step 2A to the Drawer System using four M6 x 16 Hex Bolts, four M6 Spring Washers and four M6 x 19 Flat Washers (Items 20, 21, 22) as shown.

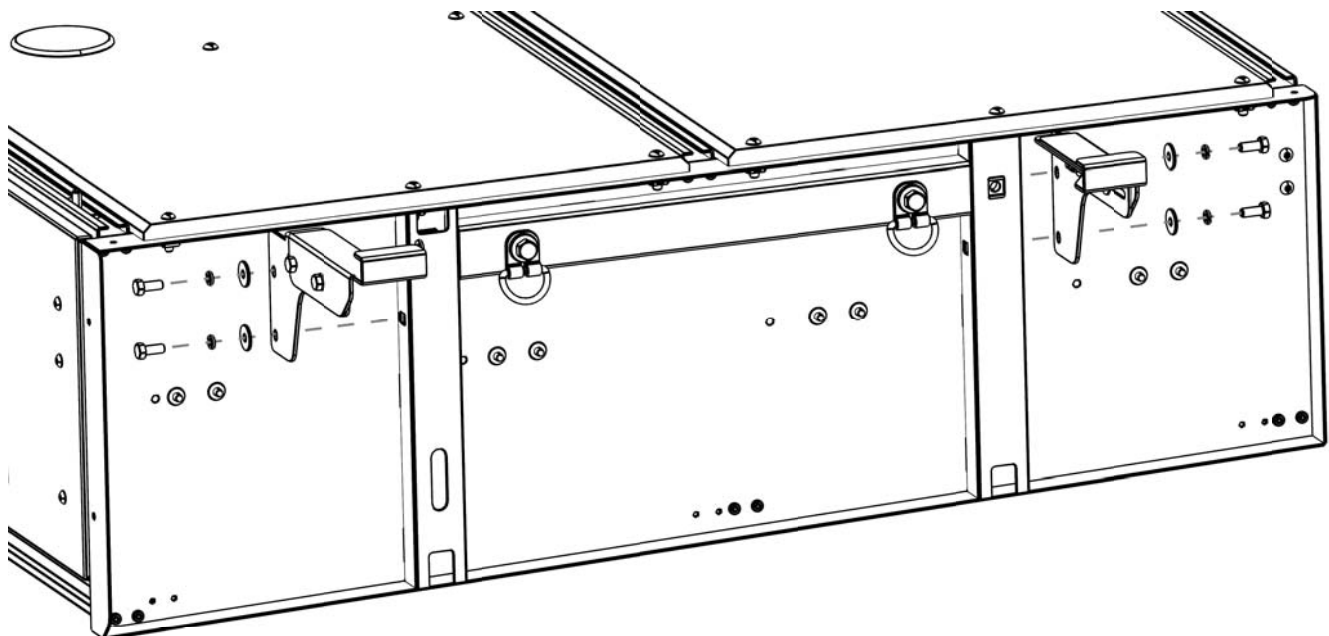

3 INSTALL DRAWER SYSTEM CONT...

- (F) Secure the Left and Right Front Faces (Item 23) to the Drawer System using four M5 x 12 Button Head Bolts, four M5 Flat Washers and four M5 Nyloc Nuts (Items 18, 19, 20) as shown.

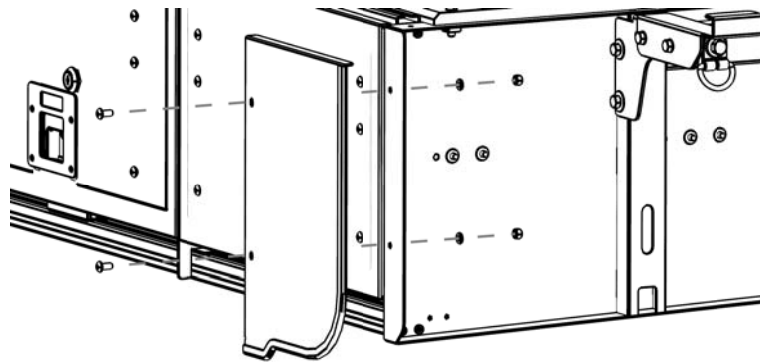

- (G) Fit the Side Decks (Items 15 & 16) to the Drawer System by "clipping " them into the Wings.

- (H) Congratulations, you have completed your installation. Take a step back and admire your work. Good Job!



4 INSTALL OTHER VEHICLE AND RACK ACCESSORIES

- (A) Now's the time to visit your favorite Front Runner dealer in person or online.