

AIRBAG PURGE CONTROL KIT

WARNING

- ◆ This product must be installed exactly as per these instructions using only the hardware supplied.
- ◆ Do not use this product for any vehicle make or model, other than those specified by ARB.
- ◆ This product or its fixing must not be modified in any way.
- ◆ The installation of this product may require the use of specialised tools and/or techniques.
- ◆ This product must only be installed by trained personnel.
- ◆ These instructions are correct as at the publication date. ARB Corporation Ltd. cannot be held responsible for the impact of any changes subsequently made by the vehicle manufacturer.
- ◆ During installation, it is the duty of the installer to check correct operation/clearances of all components.
- ◆ Work safely at all times.

Note: These fitting instructions should be read in conjunction with the vehicle workshop manual or torque reference chart.

FITTING REQUIREMENTS

HAND TOOLS REQUIRED

Ring open end spanner set metric
Socket set metric
Air tube cutter
Allen key set metric
Screwdriver

WORKSHOP TOOLS REQUIRED

Vehicle hoist or jack and axle stands

OPTIONAL HAND TOOLS

Ratchet spanners metric

CONSUMABLE

Soapy water
Teflon/ PTFE Tape *
Thread Sealant *

**Use Teflon tape or thread sealant for fittings wherever applicable.*

SAFTEY EQUIPMENT REQUIRED

Protective eyewear







Hearing protection

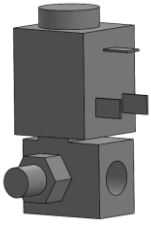
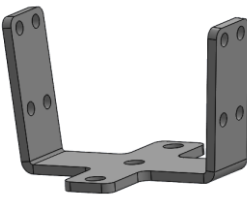

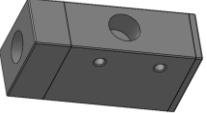
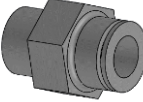
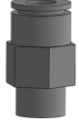
PART LIST

ITEM	PART NUMBER	NAME	QTY	
1	3460030	PURGE CONTROL KIT	1	
2	180106	SOLENOID VALVE	1	
3	3750831	PURGE VALVE BRKT	1	

PURGE CONTROL KIT CONTENTS			
ITEM	NAME	QTY	
AF1	PURGE VALVE	2	
AF2	STRAIGHT FITTING	2	
AF3	STRAIGHT FITTING	3	
AF4	UNION Y	1	

FASTENERS				
ITEM	PART NUMBER	NAME	QTY	
F1	6152008	BOLT FLANGE M6x25	2	
F2	6151561	NUT FLANGE M6	2	
F3	6151126	SCREW M4x30	4	
F4	6151404	NUT FLANGE M4	4	
F5	6151730	BOLT FLANGE M8x20	1	
F6	6151548	NUT FLANGE M8	1	



Open the kit and check all the parts as per the lists above

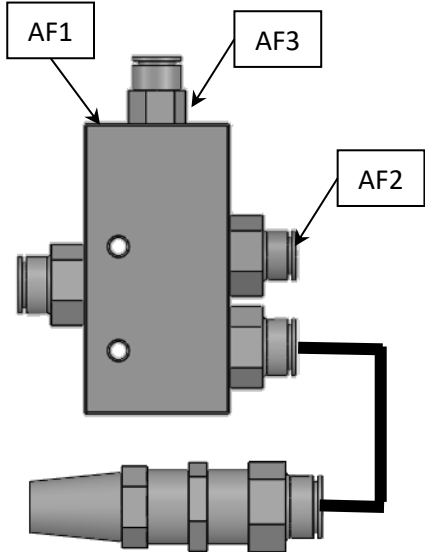

Fit Air fittings to the purge valves

Straight air fittings, connectors and silencers come from Basic Airbag kit

Part:
AF1&AF2&AF3

Fastener:

Tool:
open spanner
12 & 17

Torque:
Hand-torque

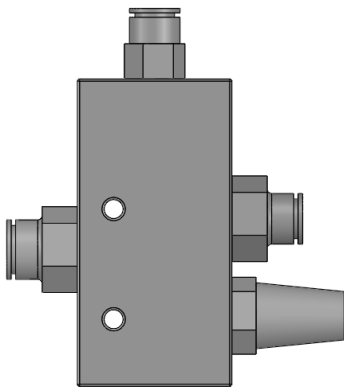

The silencer from Basic Airbag kit can be directly fitted to the purge valve if the location is suitable for purging air.

Part:

Fastener:

Tool:
open spanner
12 & 17

Torque:
Hand-torque

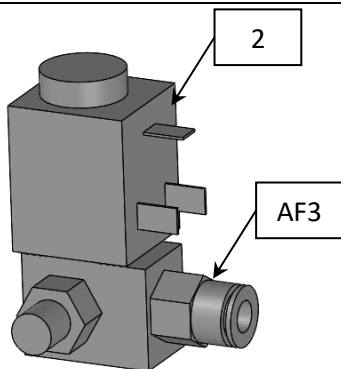

Fit Air fittings to the solenoid valve

Part:
2 & AF3

Fastener:

Tool:
socket 12

Torque:
Hand-torque

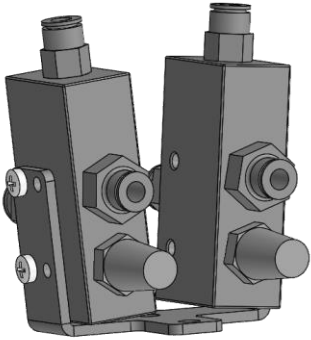
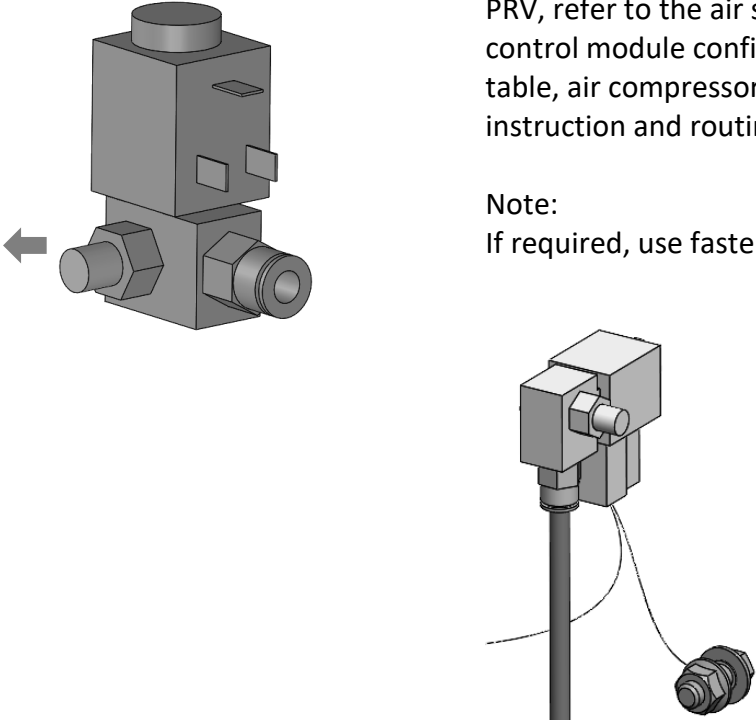
	<p>Mount purge valves to the bracket using 4-M4 screws & nuts.</p> <p>Use M6 bolts & nuts to mount the whole assembly. Recommend to mount valves in the canopy, passenger cabin or engine bay.</p> <p>Note: Please apply thread lock or adhesive to secure the nuts in place.</p>	<p>Part:</p> <p>Fastener: F1, F2, F3, F4</p> <p>Tool: Screw driver</p> <p>Torque:</p>
	<p>Connect the solenoid valve to the PRV, refer to the air suspension control module configuration table, air compressor system fitting instruction and routing schematic.</p> <p>Note: If required, use fasteners F5 & F6.</p>	<p>Part:</p> <p>Fastener:</p> <p>Tool:</p> <p>Torque: Hand-torque</p>

There are three options to manage the inflation and deflation of the airbags:

- 1) Manual control mode where you can use the inflation and purge (deflation) valve for each airbag separately.
- 2) App-controlled mode for inflation with manual or app control for deflation (purge) of airbags.
- 3) Linx control mode for inflation and manual or app control for deflation (purge).

Based on the control module configuration selected, complete the routing. There are two different routing options provided for configuration 1 & 2 highlighted.

Air Bag Control Module Configurations

Manual										
Sr. No.	Operation Mode	Control Mode	Purge Mode	Configuration	Air Bag Kit	OME Purge Control Kit	Air Suspension Module	LINX Pressure Control Kit	LINX Air Suspension Isolation Kit	Other Parts
A	Manual	Manual	Manual	Independent Air Bag with Purge (Ball) Valve	OMEAB00x	NA	NA	NA	NA	NA

App Controlled										
Sr. No.	Operation Mode	Control Mode	Purge Mode	Configuration	Air Bag Kit	OME Purge Control Kit	Air Suspension Module	LINX Pressure Control Kit	LINX Air Suspension Isolation Kit	Other Parts
A	Pressure Operated	APP	Manual	One airline split to control 2 air bag pressures in isolation with no pathway between them. However, pressure will be same.	OMEAB00x	NA	1 X 0830002	NA	NA	NA
1	Pressure Operated	APP	APP	PURGE + One airline split to control 2 air bag pressures in isolation with no pathway between them. However, pressure will be same.	OMEAB00x	OMEABK001	1 X 0830002	NA	NA	NA

LINX Controlled										
Sr. No.	Operation Mode	Control Mode	Purge Mode	Configuration	Air Bag Kit	OME Purge Control Kit	Air Suspension Module	LINX Pressure Control Kit	LINX Air Suspension Isolation Kit	Other Parts
A	Pressure Operated	LINX	Manual	One airline split to control 2 air bag pressures independently with no pathway between them	OMEAB00x	NA	NA	1 x 7450107	1 x 7450109	NA
2	Pressure Operated	LINX	LINX	PURGE + One airline split to control 2 air bag pressures independently with no pathway between them	OMEAB00x	OMEABK001	NA	1 x 7450107	1 x 7450109	1 X 180425

CONFIGURATION 1 & 2: ROUTING 1

*** REFER TO AIR COMPRESSOR SYSTEM FITTING INSTRUCTIONS.

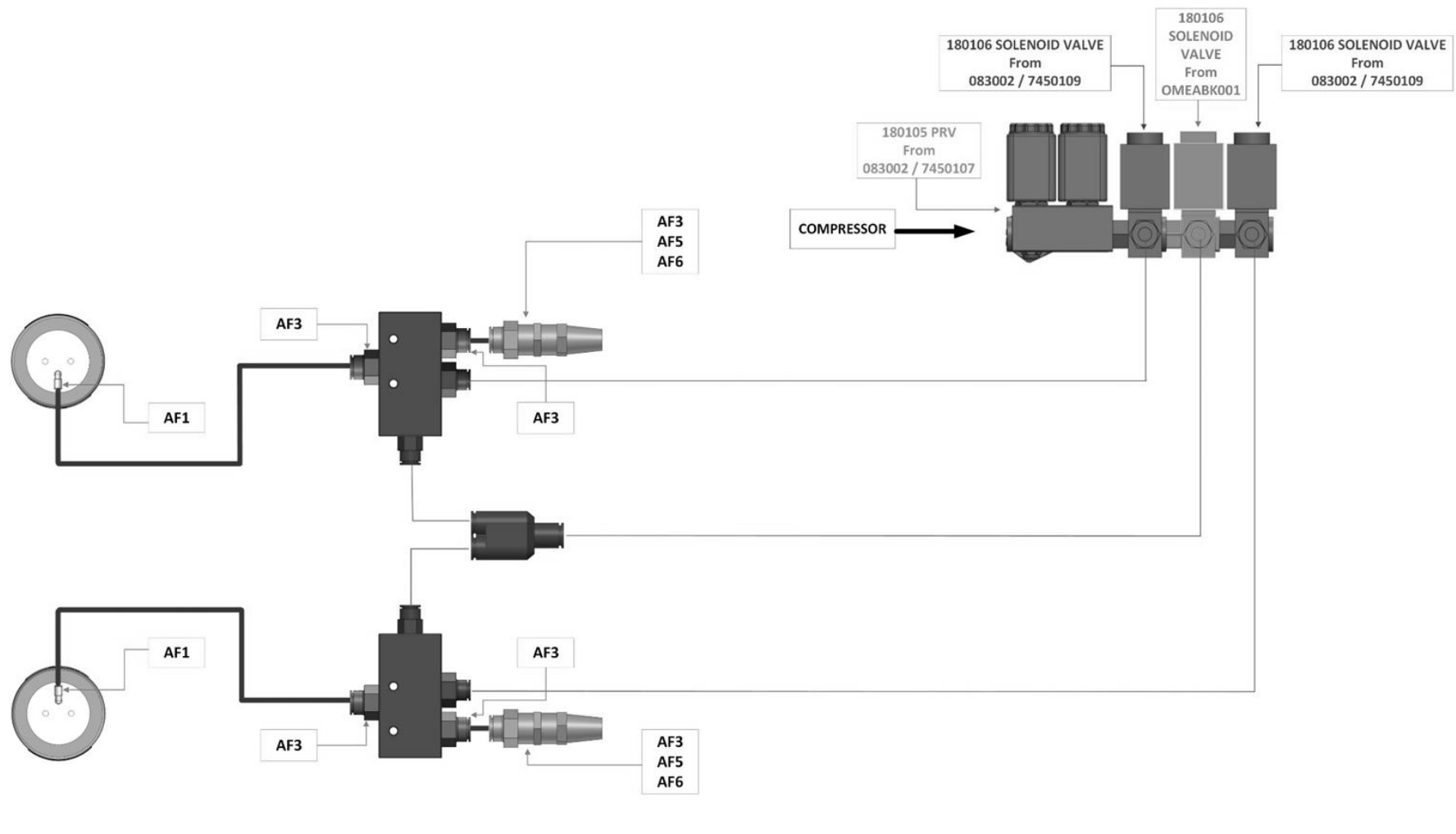

*** STRAIGHT AIR FITTINGS, UNION Y, PURGE VALVES, SOLENOID VALVE COME FROM OME PURGE CONTROL KIT (OMEABK001).

— 8mm AIR LINE — 6mm AIR LINE

CONFIGURATION 1 & 2: ROUTING 2

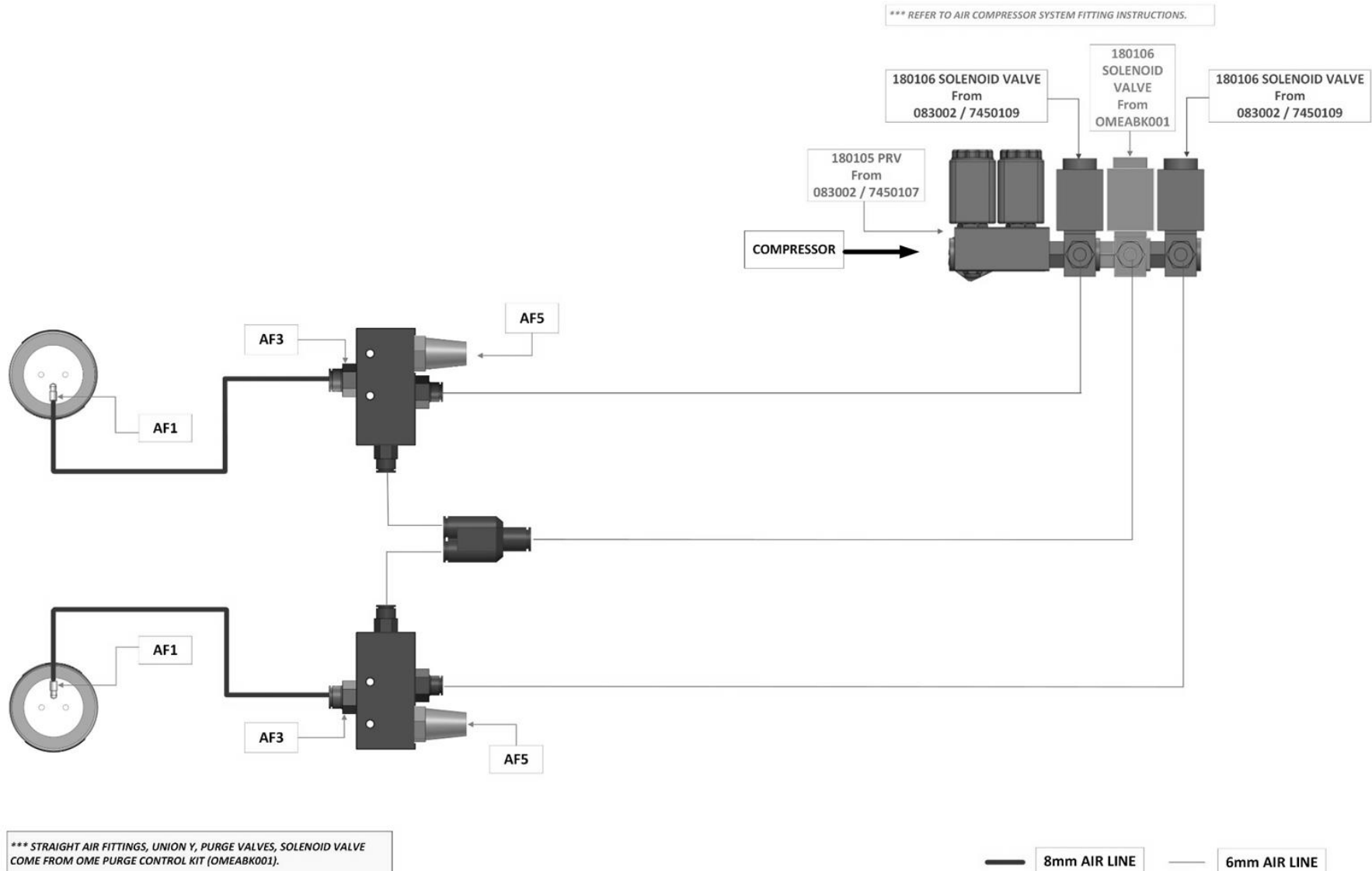

<p>Connect all the air fittings as per the programs.</p> <p>Use a tube cutter to cut all the air tubes. Do not use side cutter or similar tools, because they may deform the tube and cause a leak.</p>	<p>Part: AF2</p> <p>Tool: Spanner 12&17 Tube cutter Soapy water</p> <p>Torque: Hand-torque</p>
---	--

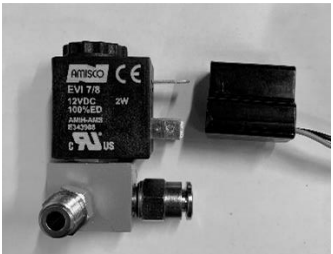
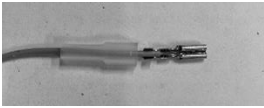
 	<p>Connect the purge valve solenoid to the LINX/APP control unit. Refer to the LINX/APP instructions. For the LINX control, an extra 180425 wiring harness needs to be ordered.</p>	<p>Part:</p> <p>Fastener:</p> <p>Tool:</p> <p>Torque:</p>
<p>Refer to the LINX/APP manual, Install the airbag purge programme.</p>		