

# **ARB** **BASE RACK**

## **FITTING INSTRUCTION**

Part Number:                      Suits BASE RACK:  
**17914050**                            **1770060/70**  
**17914070**                            **1770060/70**

Product Description:    **BASE RACK fitting kit suits HILUX 150N**

## **WARNING**

### **NOTE THE FOLLOWING:**

- ◆ Vehicle accessories which are not properly fitted can be dangerous.
- ◆ Please read these instructions carefully prior to fitting, and comply with the instructions at all times
- ◆ If in any doubt please contact your nearest ARB state office or the stockist from whom it was purchased.
- ◆ Do not use this product for any vehicle make or model, other than those specified by ARB.
- ◆ This product or its fixing must not be modified in any way.
- ◆ The installation of this product may require the use of specialized tools and/or techniques
- ◆ It is recommended that this product is only installed by trained personnel
- ◆ These instructions are correct as at the publication date. ARB Corporation Ltd. cannot be held responsible for the impact of any changes subsequently made by the vehicle manufacturer
- ◆ During installation, it is the duty of the installer to check correct operation/clearances of all components
- ◆ Work safely at all times
- ◆ Unless otherwise instructed, tighten fasteners to specified torque
- ◆ Check bolt torque after 500km & at regular service intervals

## **ARB 4x4 ACCESSORIES**

### **Corporate Head Office**

42-44 Garden St  
Kilsyth, Victoria  
AUSTRALIA 3137

Tel:    +61 (3) 9761 6622  
Fax:    +61 (3) 9761 6807

Australian enquiries  
North & South American enquiries  
Other international enquiries

sales@arb.com.au  
sales@arbusa.com  
exports@arb.com.au

**[www.arb.com.au](http://www.arb.com.au)**

# SAFETY

## NET PAYLOAD FOR YOUR BASERACK

The net payload for your BASE RACK is calculated by subtracting the weight of the BASE RACK and the vehicle mounting kit from the vehicle's roof capacity. The table below gives the BASE RACK net payload for fitting kit 17914050, using the vehicles maximum vehicle roof capacity. The vehicle's roof load capacity may vary between models and driving conditions. Refer to vehicle owner's manual for model and condition specific roof load capacities.

Kit	BASE RACK	Vehicle roof capacity* (kg/lb)	BASE RACK + mount kit (kg/lb)	BASE RACK net payload (kg/lb)
17914050/70	1770060	60 / 132	20 / 44	40 / 88
17914050/70	1770070	60 / 132	21 / 46	39 / 86

\* Maximum roof load capacity. Refer to vehicle owner's manual for model and condition specific roof load capacities.

It is important to follow the listed usage instructions;

- ◆ Maximum load per BASE RACK beam is 25kg.
- ◆ Load must be evenly distributed and adequately secured.
- ◆ Any weight carried on the roof of the vehicle will adversely affect its handling, particularly in cornering or in a cross-wind, the vehicle should therefore be driven with increased discretion.
- ◆ Regularly check the tightness of the securing clamps and the security of the load.
- ◆ Attention is directed to statutory requirements regarding maximum permissible projections from vehicles.

All bolts should be checked prior to touring to ensure the tray is fastened correctly

## **GENERAL CARE AND MAINTENANCE**

By choosing an ARB BASE RACK, you have bought a product that is one of the most sought after 4WD products in the world. Your BASE RACK is a properly engineered, reliable, quality accessory that represents excellent value. To keep your BASE RACK in original condition it is important to care and maintain it following these recommendations:

- ◆ As part of any pre-trip preparation, or on an annual basis, it is recommended that a thorough visual inspection of the BASE RACK is carried out, making sure that all bolts and other components are torqued to the correct specification. Replace any components as necessary.

Please contact local Authorised ARB Stockist if you would like to have this service carried out on your behalf.

## FITTING REQUIREMENTS

### REQUIRED TOOLS FOR FITMENT OF PRODUCT:

BASIC TOOL KIT	Vacuum Cleaner
Allen key set	Torque Wrench
Pen/pencil	Pistol Drill
Tape measure	Ø6.5mm drill

**NOTE: 'WARNING' notes in the fitting procedure relate to OHS situations, where to avoid a potentially hazardous situation it is suggested that protective safety gear be worn or a safe work procedure be employed. If these notes and warnings are not heeded, injury may result.**

### FASTENER TORQUE SETTINGS:

SIZE	Torque Nm	Torque lbft
M6	9Nm	7lbft
M8	22Nm	16lbft
7/16 UNF seat belt bolts	40Nm	29.5lbft

### Air Deflector and Base Rack Light Bar



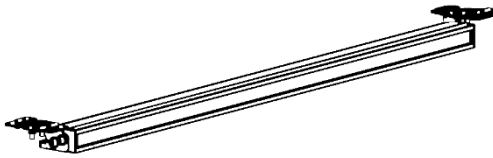



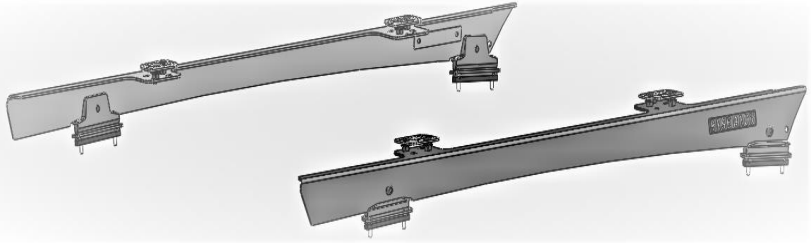

An air deflector or BASE RACK Light Bar should be fitted beneath the front edge of the BASE RACK. Refer to the table below for the correct part number. If fitting the light bar it must be under the BASE RACK, an Air Deflector is not needed if Light bar is fitted. Refer to the instructions provided with these products for further details.

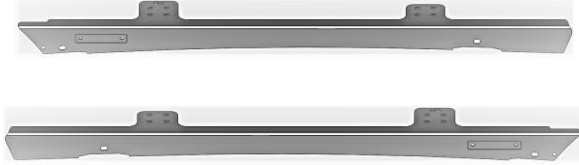
		PART NUMBER	BASE RACK FITTING KIT
AIR DEFLECTOR		17914060	17914050
BASE RACK LIGHT BAR		1780500	17914050

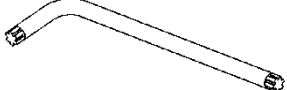

### PARTS LISTING - BASE RACK fitting kit

PART NUMBER	SUITS BASE RACK	QTY	DIAGRAM
17914050 17914070	1770060 1770070	1	

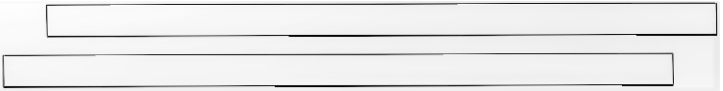
## PARTS LISTING

PART NO.	PICTURE	QTY	DESCRIPTION
<b>APPLICATION – MOUNTING BRACKETS TO ROOF</b>			
3750690L OR 3753919L 3750690R OR 3753919R		1  1	<b>BLADE BRACKET HILUX LH</b>  <b>BLADE BRACKET HILUX RH</b>
6317651		4	<b>DUAL CAR MNT FOOT</b>
6151398		8	<b>SCREW BUTTON HEAD M6 X 40mm S/S</b>
6151046		8	<b>M6 FLAT WASHER</b>
6151162		8	<b>NYLOC NUT M6</b>
3193759		4	<b>CLAMP PLATE DUAL CAB</b>
5848501		4	<b>RUBBER PACKER R'RACK</b>
6151934		1	<b>TORX ALLEN KEY</b>
6151924		4	<b>M8 X 1.25 X20 BUTTON HEAD TORX - BLK</b>
4581085		4	<b>M8 WASHER FLAT - BLACK</b>
6781408		2	<b>TAPE DOUBLE SIDED 0.8X15X300</b>

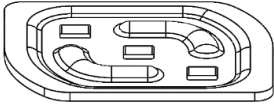
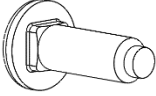
**APPLICATION – BASE RACK TO MOUNTING BRACKETS**

3195184		4	<b>M8 STUD PLATE</b>
6151921		8	<b>M8 STUD - BLACK</b>
6151212		8	<b>M8 X 1.25 NYLOC NUT - BLACK</b>
4581085		8	<b>M8 WASHER FLAT - BLACK</b>

## FITTING PROCEDURE



1. Remove the sun visors. Remove the EIGHT grab handles from the pillars.



2. Remove the plugs located around the periphery of the ceiling. They are located at the front at the driver's side, the rear of the ceiling at the right & left side of the vehicle and above the rear windscreen.



3. Remove the interior light.



4. Carefully remove centre roof console and unplug.



5. Pull down the door seals so the interior trim can be removed.



6. Remove the front and rear top seatbelt mounts. Do not use power tools to remove or install seatbelt hardware.



7. Remove the plastic trim from the front, middle and rear pillars on each side of the vehicle. They can simply be pulled away to be released from their mounting clips.



8. Carefully lower the headlining as shown in the adjacent diagram. It does not need to be totally removed.

## FITTING PROCEDURE

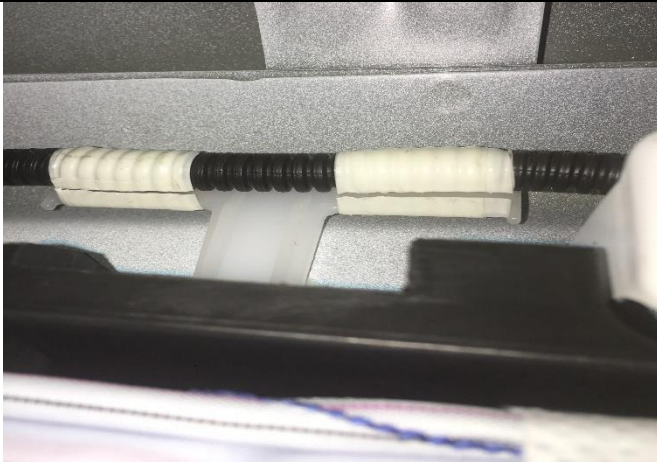

9. Once you can gain access behind the liner roughly gauge where the **rear** mounting feet will be located (explained in step 11). The tape holding spiral tubing will need to be cut in order for it to be moved out of the way so it is not damaged whilst drilling and during the installation. Once the installation is complete this can be reattached using tape.



10. Remove the exterior roof trim from both sides of the vehicle. Take care not to bend the trim, as it will be reused.

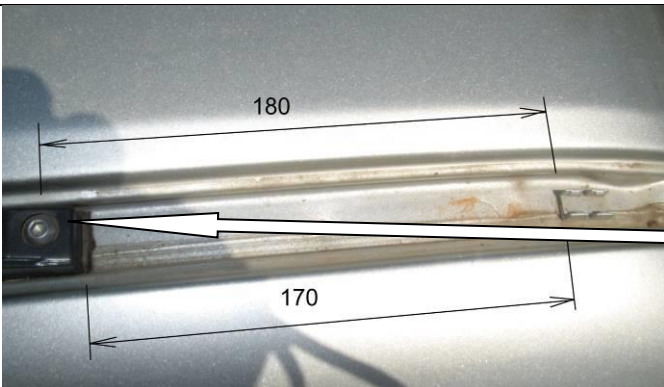

11. Position the rear mounting blocks as shown. Use a steel rule to locate the rear face of the rear mounting block 170mm from the roof trim clip as shown.

12. Once satisfied that the block is accurately positioned, use the block as a template to drill its rear-mounting hole through the roof of the vehicle with a 6.5mm drill bit.

13. Next, fasten the block to the roof, using the newly drilled hole, with a M6 x 40 pan head bolt and nyloc nut. Proceed to drill the second mounting hole for the block, again using each block as a template for the drill. Undo the M6 bolt and remove the roof-rack mounting block.

14. Repeat steps 11 – 13 for the front mounting blocks, except this time rear face is 1070mm from the roof trim clip.





15. Remove all burrs and sharp edges from the newly drilled holes.

16. Paint the holes with rust prevention paint.

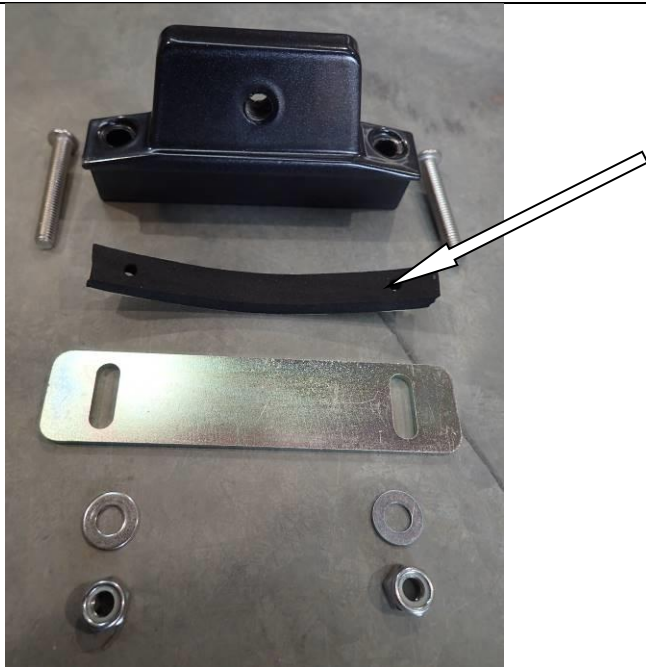

17. Cut the Foam packers to suit the mount blocks and stick to the bottom of the foot.

18. Apply a small amount of silicon to the underside of the screw heads of the M6 x 40 button head screws.



19. Place the foam gasket & mounting block onto the vehicle roof. Feed the M6 x 40 button head bolts through the mounting blocks and vehicle roof.

20. On the underside of the roof fit the clamping plate, flat washers and nyloc nuts and tighten the nut to specification.

Use the same hardware for all four rack-mounting blocks.



## OPTIONAL STEP

**If fitting a BASE Rack Wiring Kit refer to the last page, install it now**



21. Cut the roof trim that was removed earlier at step 10 to fit neatly around the roof rack mounting blocks. There will be six pieces in total for both sides of the roof.

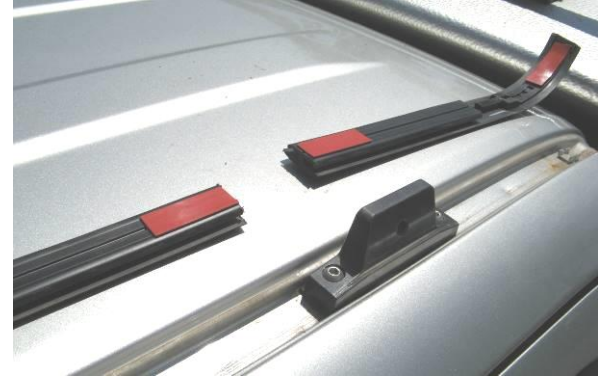

22. The fitting kit includes two pieces of double-sided tape to be cut into equal lengths of 50mm (12 pieces). Apply tape to each end of the roof trim pieces and stick the roof trim back in place by following steps 1 – 8 in reverse order. Make sure the seat belt bolt is torqued to specification.

 **7/16 UNF - 40Nm**

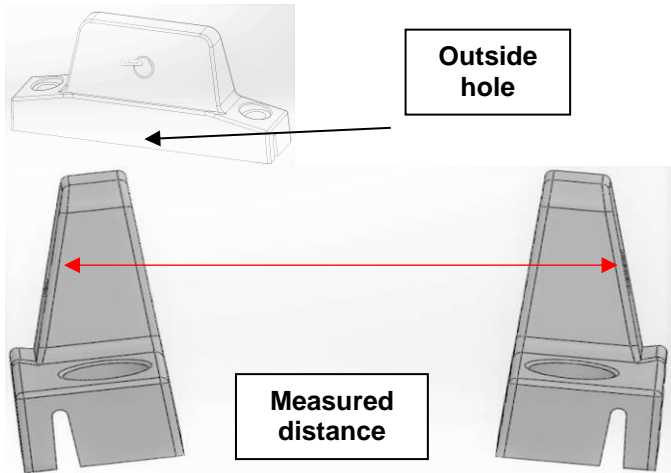

23. Using a tape measure, measure across the vehicle between the middle of the hole on the outside face of the front and rear set of mounting brackets. Make a note of each measurement.

Position	Distance
Front	
Rear	

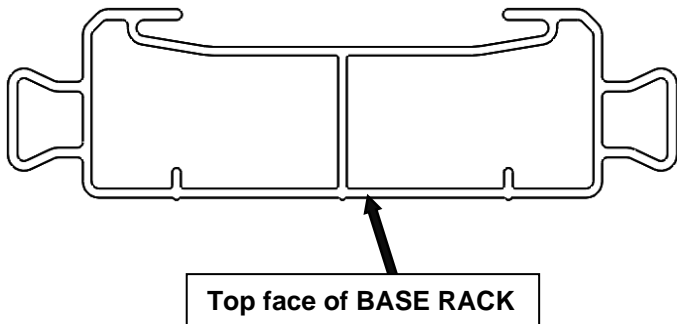

24. Place the BASE RACK face down on a clean flat surface. Provide protection to the top face of BASE RACK to avoid marking of surfaces

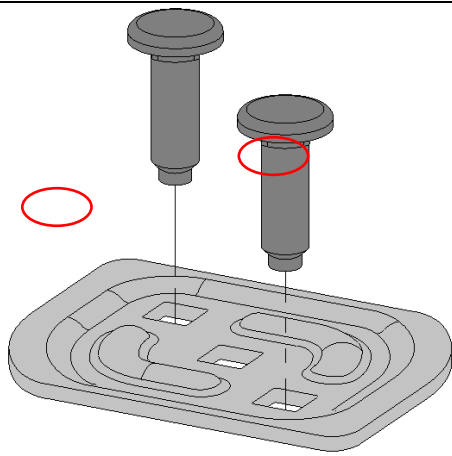

25. Insert 2, M8 x 20 Studs into 4 of the Stud Plates as shown.

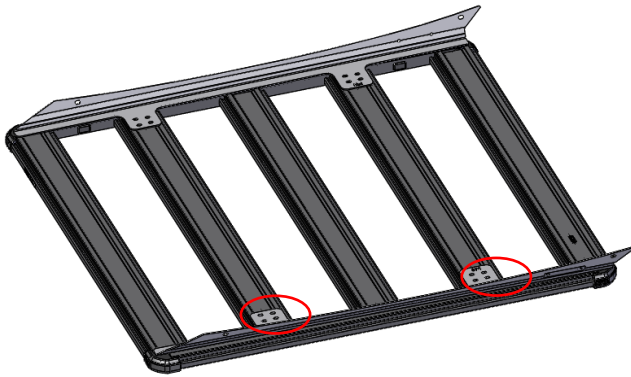

26. Check the position of the mounting plates (circled in image) on the blade brackets in relation to the channels on the BASE RACK.

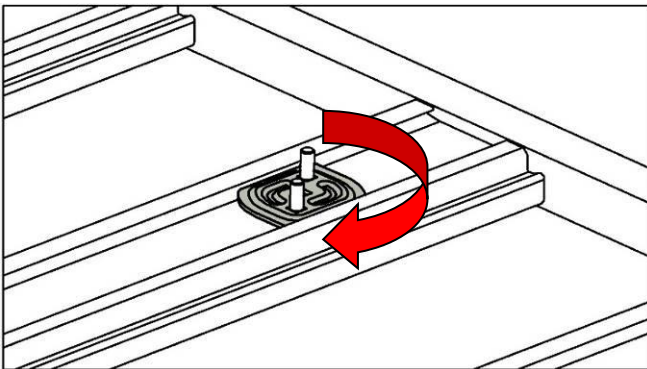

27. Insert the previously assembled stud plates into the correct BASE RACK channels. Rotate the plates 90 degrees.

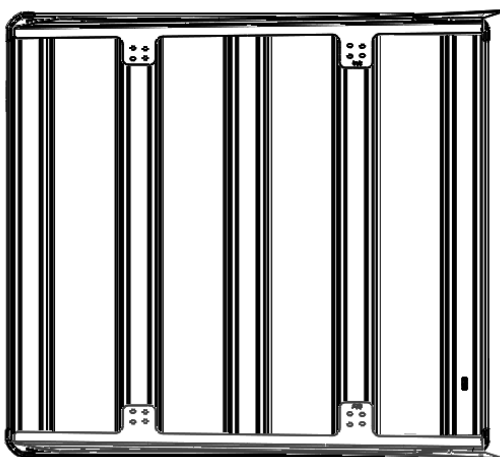

28. Flip the blade brackets over so they are upside down and carefully place on top of the BASE RACK. When doing so ensure the M8 studs in the stud plates go through the slots. Then secure the blade brackets to the BASE RACK using M8 flat washers and nyloc nuts. Do not fully tighten, allowing each blade to move.

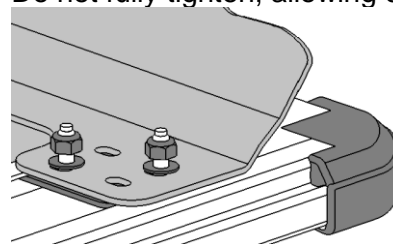

*Generic Image*

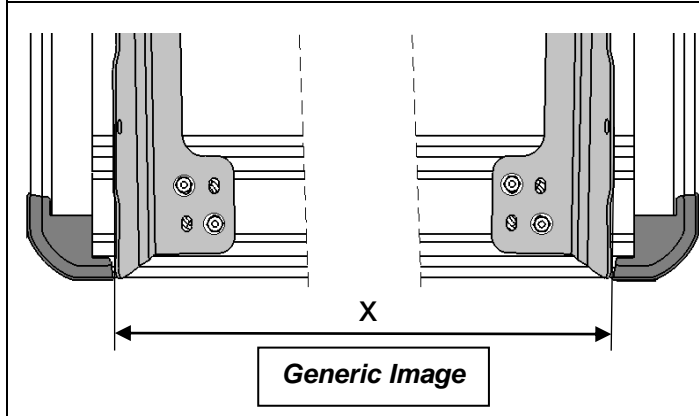
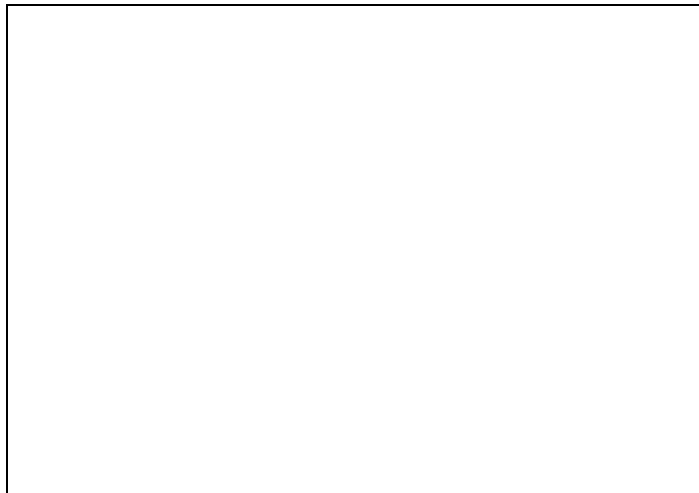

29. Using the previously recorded measurements, adjust the location of the blade bracket on the BASE RACK.

Ensure the distance between the blade bracket and the edge of the tray is the same on both sides. Fully tighten all M8 nyloc nuts to specified torque.

 **M8 - 22Nm**

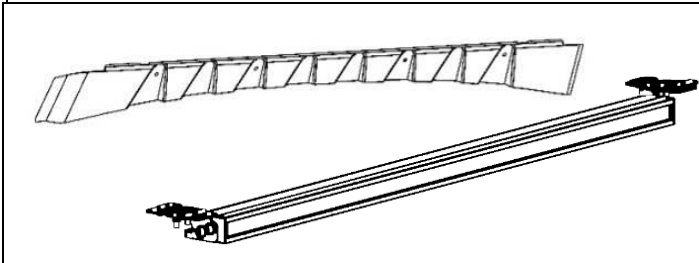

30. If fitting an air deflector or BASE RACK lightbar it should be fitted to the BASE RACK at this point. Refer to instructions provided with the air deflector or BASE RACK light bar for fitting details.

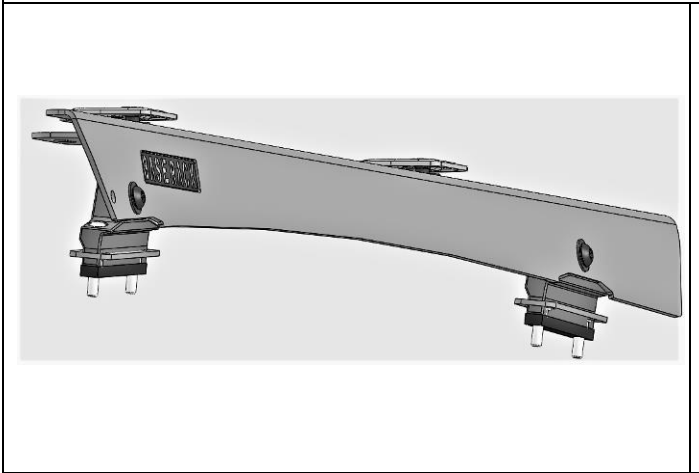

31. With assistance, carefully place the BASE RACK on the vehicle so the inside of the blade brackets rests on the outside of the mounting blocks. The entire BASE RACK assembly should be clear of the vehicle roof. All mounting holes/slots should align closely.

Note: Place protective material on roof to reduce the risk of accidental damage to vehicle when mounting the BASE RACK to the vehicle.

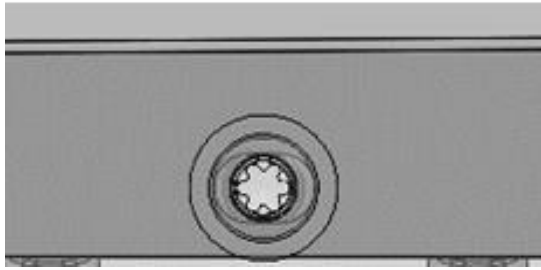

32. Confirm BASE RACK is correctly aligned to vehicle. If it is not it is recommended to remove the BASE RACK from the vehicle roof and repeat the mounting process from the measurement step #23.

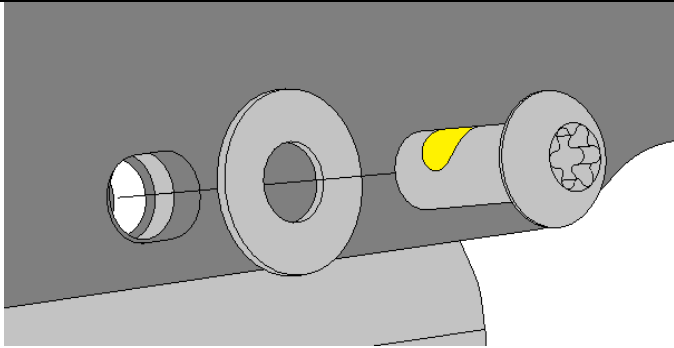

33. Use the M8 Button head Torx screws and M8 Black washers to secure the BASE RACK to the roof mounting brackets. Tighten all screws to the specified torque.

34.  **M8 - 22Nm**



## OPTIONAL STEP FOR BASE RACK WIRING KIT (1780400 & 1780410 SOLD SEPARATELY)

These steps are a vehicle specific supplement to the main instruction, this instruction should be used in parallel. Read and both instructions before proceeding

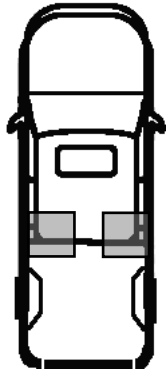

1. The recommended location for the wiring kit for this vehicle is the rear, left or right hand side
2. The location provided has been chosen to provide a safe passage away from vehicle components (airbags, vents, etc) and integrated to the rack

**! CAUTION – THIS STEP MAY REQUIRE DISASSEMBLY OF SEAT BELT MOUNTS AND WORK IN THE PROXIMITY OF CURTAIN AIR BAGS !**

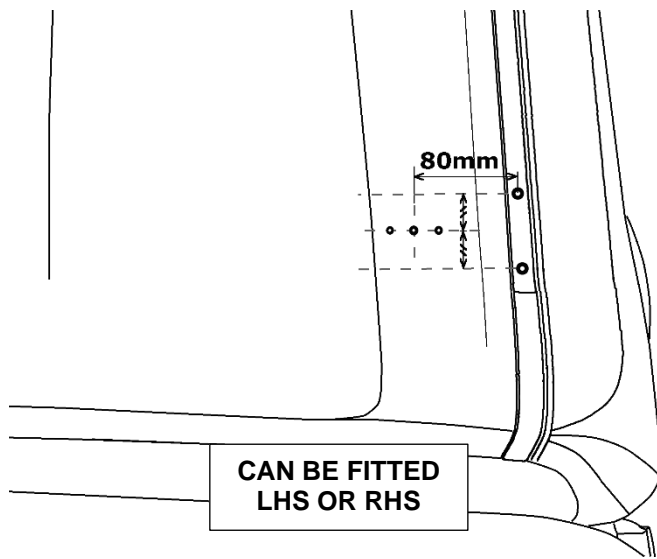

3. Mark out the hole location using the mount foot holes as a guide. Always verify they are clear inside the cabin before drilling
4. Run the wiring backward then follow and secure the existing wiring loom down the rear pillar

**ENSURE THE WIRING IS BEHIND THE AIRBAG**

**Obstruction of the airbag will prevent proper inflation and effectiveness**