

RHINO-RACK®

Batwing Awning

33114 (Left) / 33115 (Right)

Important:

1. Check the Rhino-Rack website to ensure you have the latest issue of these instructions.
2. Please refer to your fitting instruction to ensure that the roof racks are installed in the correct locations.
3. Check the contents of kit before commencing fitment and report any discrepancies.
4. Place these instructions in the vehicle's glove box after installation is complete.
5. These instructions must be followed for warranty to be upheld.

Fit Time: 15 mins

TWO-PERSON
INSTALLATION

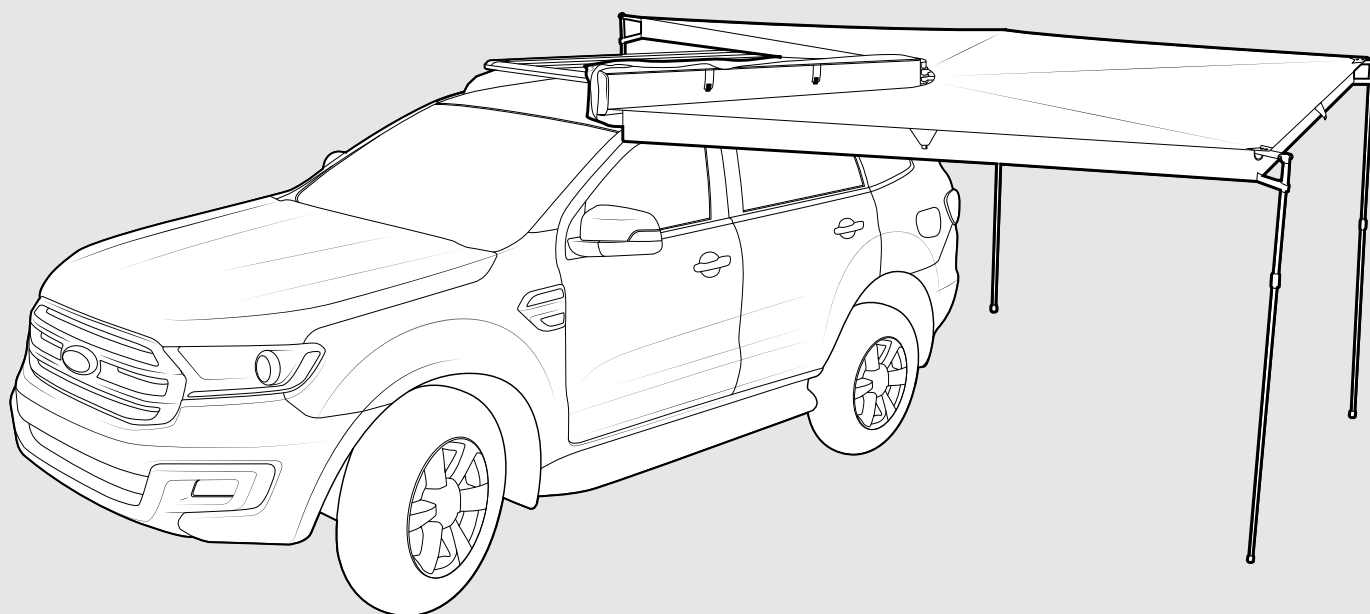

Rhino-Rack AUSTRALIA
22A Hanson Pl,
Eastern Creek, NSW, 2766

Rhino-Rack USA
Unit D, 2450 Airport Blvd,
Aurora, CO, 80011

RHINORACK.COM

Document No: R1686
Issue No: 10
Issue Date: 27/04/2023

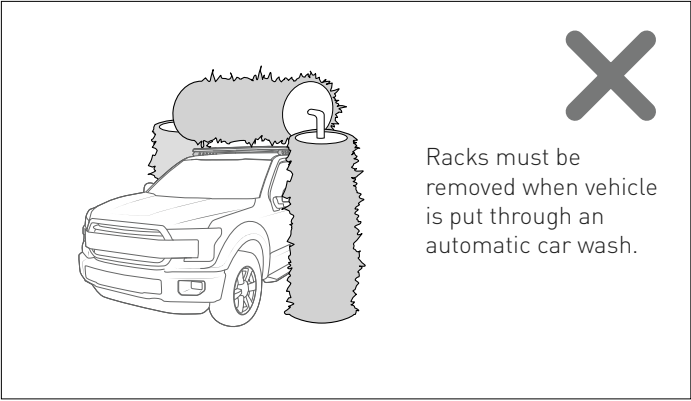

Racks must be removed when vehicle is put through an automatic car wash.

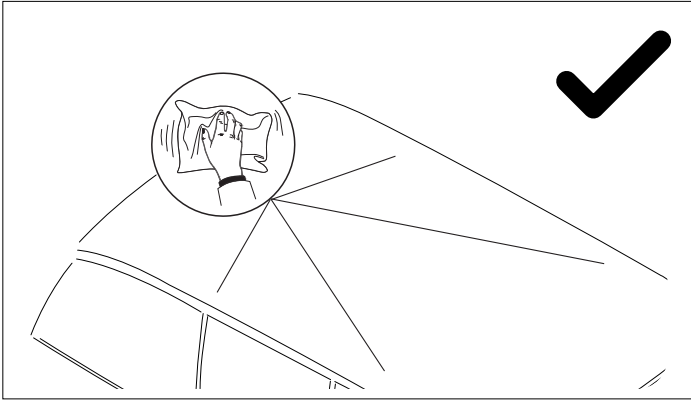

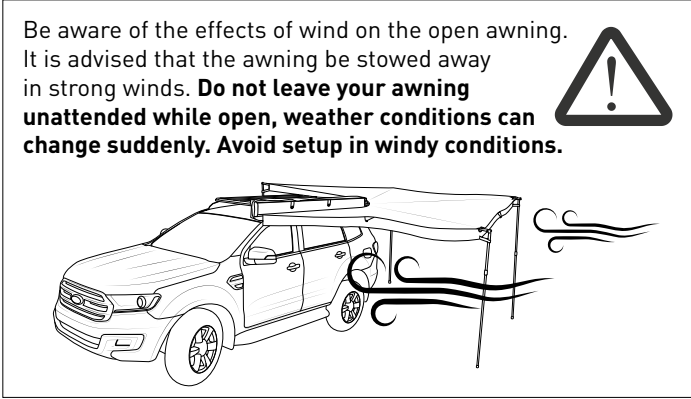
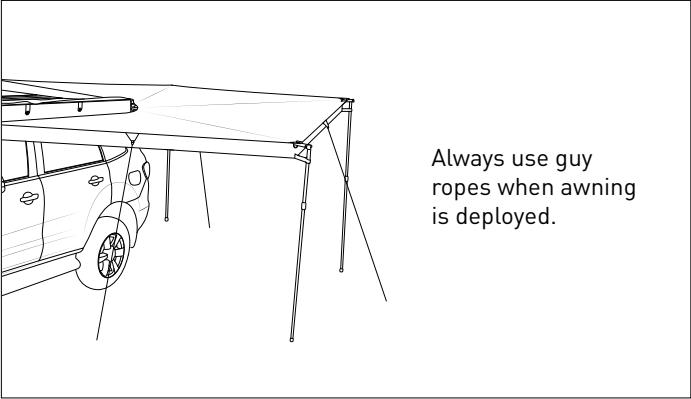

If awning is wet, dry before you stow.

Be aware of the effects of wind on the open awning. It is advised that the awning be stowed away in strong winds. **Do not leave your awning unattended while open, weather conditions can change suddenly. Avoid setup in windy conditions.**



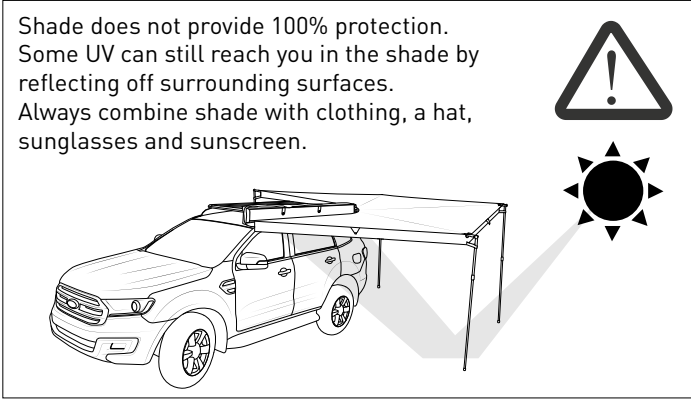
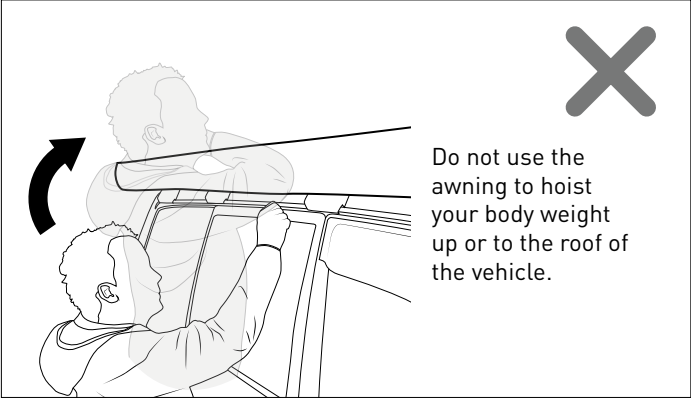

Always use guy ropes when awning is deployed.

Shade does not provide 100% protection. Some UV can still reach you in the shade by reflecting off surrounding surfaces. Always combine shade with clothing, a hat, sunglasses and sunscreen.

Do not use the awning to hoist your body weight up or to the roof of the vehicle.

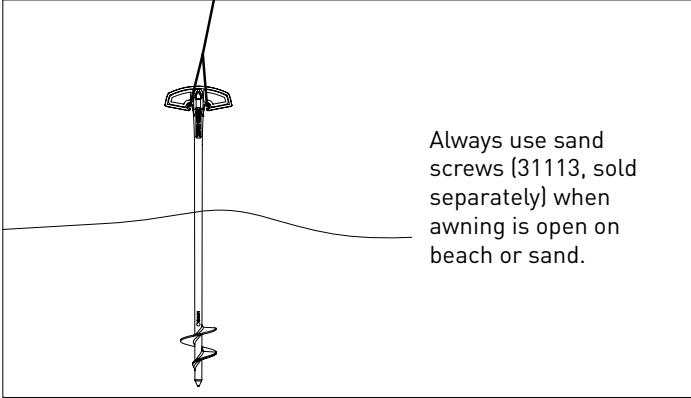

Always use sand screws (31113, sold separately) when awning is open on beach or sand.

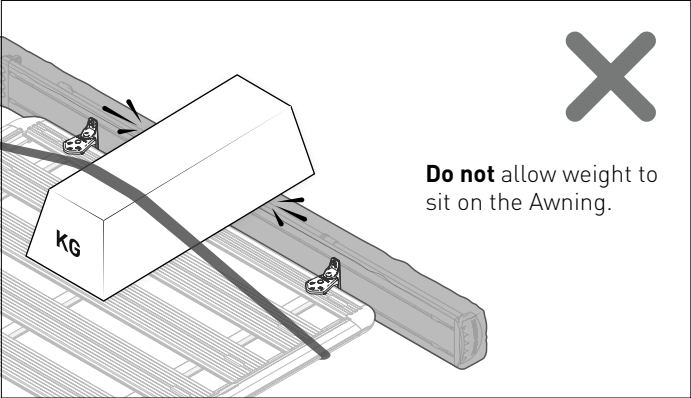

Do not allow weight to sit on the Awning.

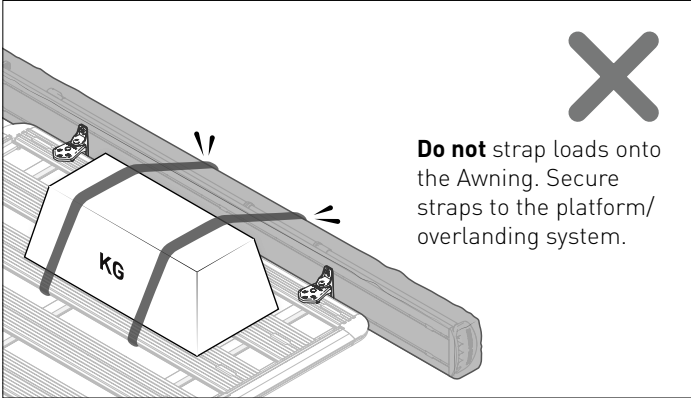

Do not strap loads onto the Awning. Secure straps to the platform/overlanding system.

Important Information

Recommendations

Use only non-stretch fastening ropes or straps.

Please remove Batwing Awning and crossbars when putting vehicle through an automatic car wash.

Do not stow away the awning for long periods if it is wet. You must allow the awning material to dry completely before storing for extended periods of time. When rolling up the awning, avoid excessive bunching up of the material before stowing. The awning should be rolled up as neatly as possible following the instruction on page 9.

In service maintenance checks

- All bolt connections should be checked after driving a short distance when you first install your roof racks.
- All bolted connections should be checked again at regular intervals (weekly is recommended, depending on road conditions, usage, loads and distances travelled).
- All bolted connections should be checked each time they are re-fitted.
- Off-road conditions are more rigorous. Check all bolted connections and your load more regularly.
- Ensure that your vehicle manufacturer's GVM, and gross axle weights are not exceeded (refer to vehicle owner's manual).

Torque Settings:

Unless stated otherwise in these instructions, all fasteners should be set to the following torque settings:

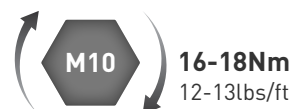

Load Ratings

With the addition of the Batwing Awning, the load capacity of your crossbars will have to be adjusted accordingly. The Batwing Awning with mounting brackets weighs approximately 20kg.

Note for Dealers and Fitters

It is your responsibility to ensure this fitting instruction is given to the end user or client. It is your responsibility to ensure these fitting instructions are given to the end user or client. These instructions remain the property of Rhino-Rack Australia Pty. Ltd. and may not be used or changed for any other purpose than intended.

Critical Dimensions

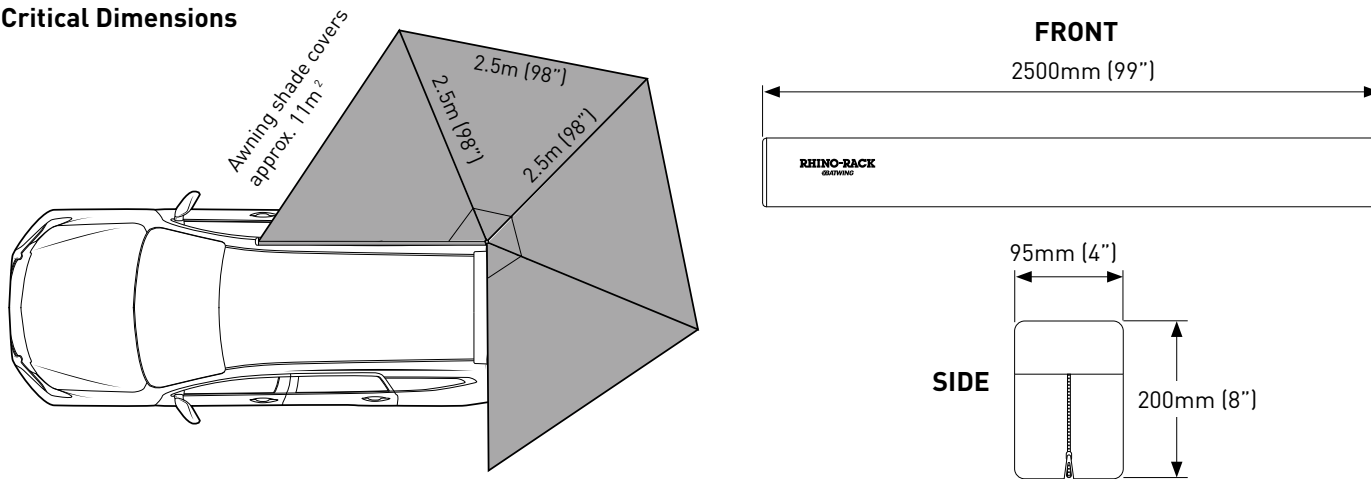

CONTENTS

Installation onto:

Pioneer Platforms ————— Steps **1 - 6** and **8 - 16**

Reconn-Deck NS Bars ————— Steps **1 - 6** and **8 - 16**

VA / HD / RD Crossbars ————— Steps **7 - 13a** and **17**

Operation ————— Steps **18 - 25**

Storage ————— Steps **26 - 29**

Maintenance & Repair ————— Page **20 - 21**

For Installation onto PIONEER PLATFORMS and RECONN-DECK NS BARS

(For Crossbars, skip to Step **7**)

1 **x2**

35 mm

P

P

40 35 40

100-006-00/21 > PAB-GF25 <

2 **x2**

O

L

P

LOOSELY ASSEMBLE

UNLOCKED

P

P

40 35 35 40

3 **x2**

P

L

P

P

4 Loosely fasten into the channel, but do not tighten.

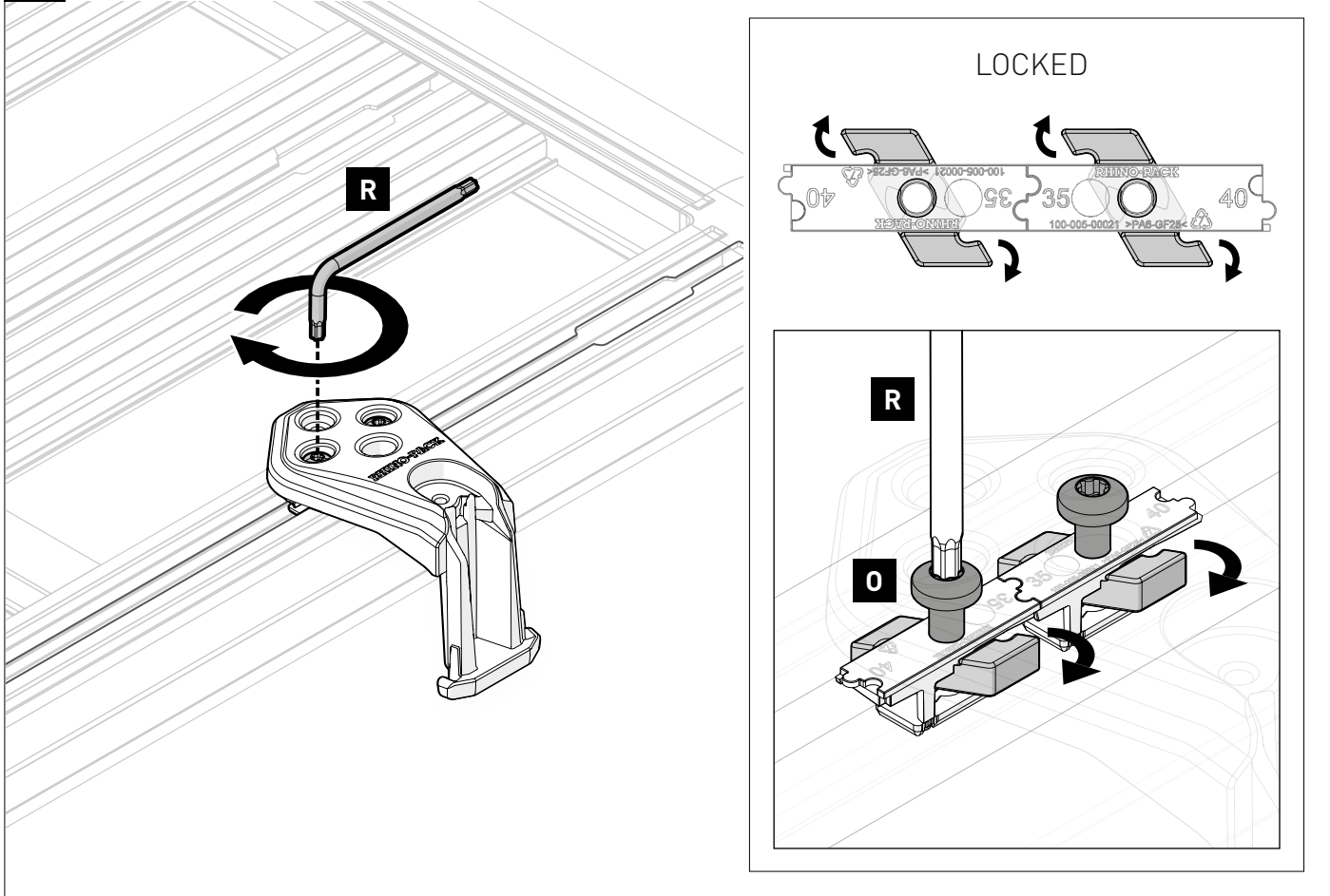

5 Move brackets to outermost edges of Platform, **avoiding channel apertures**.

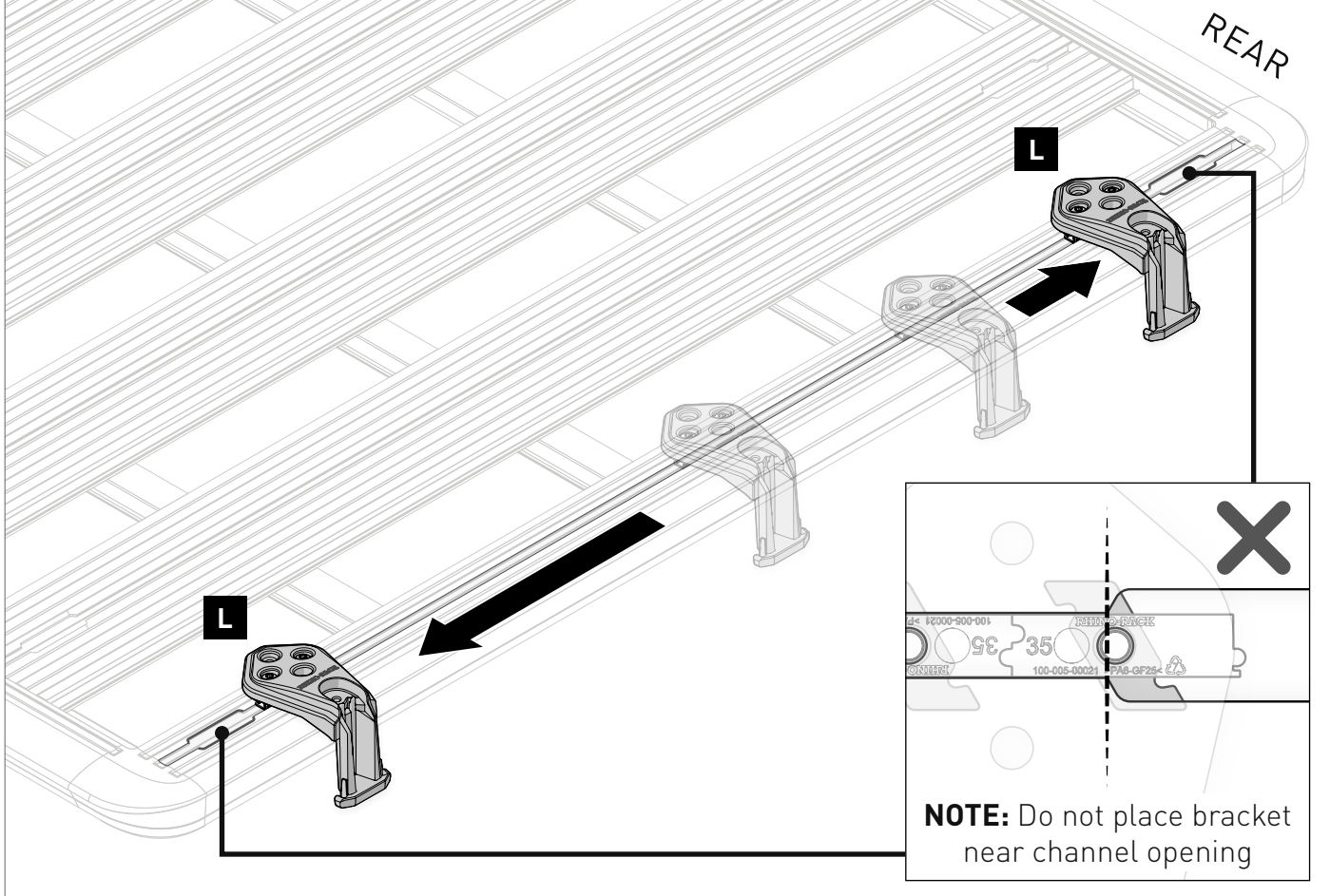

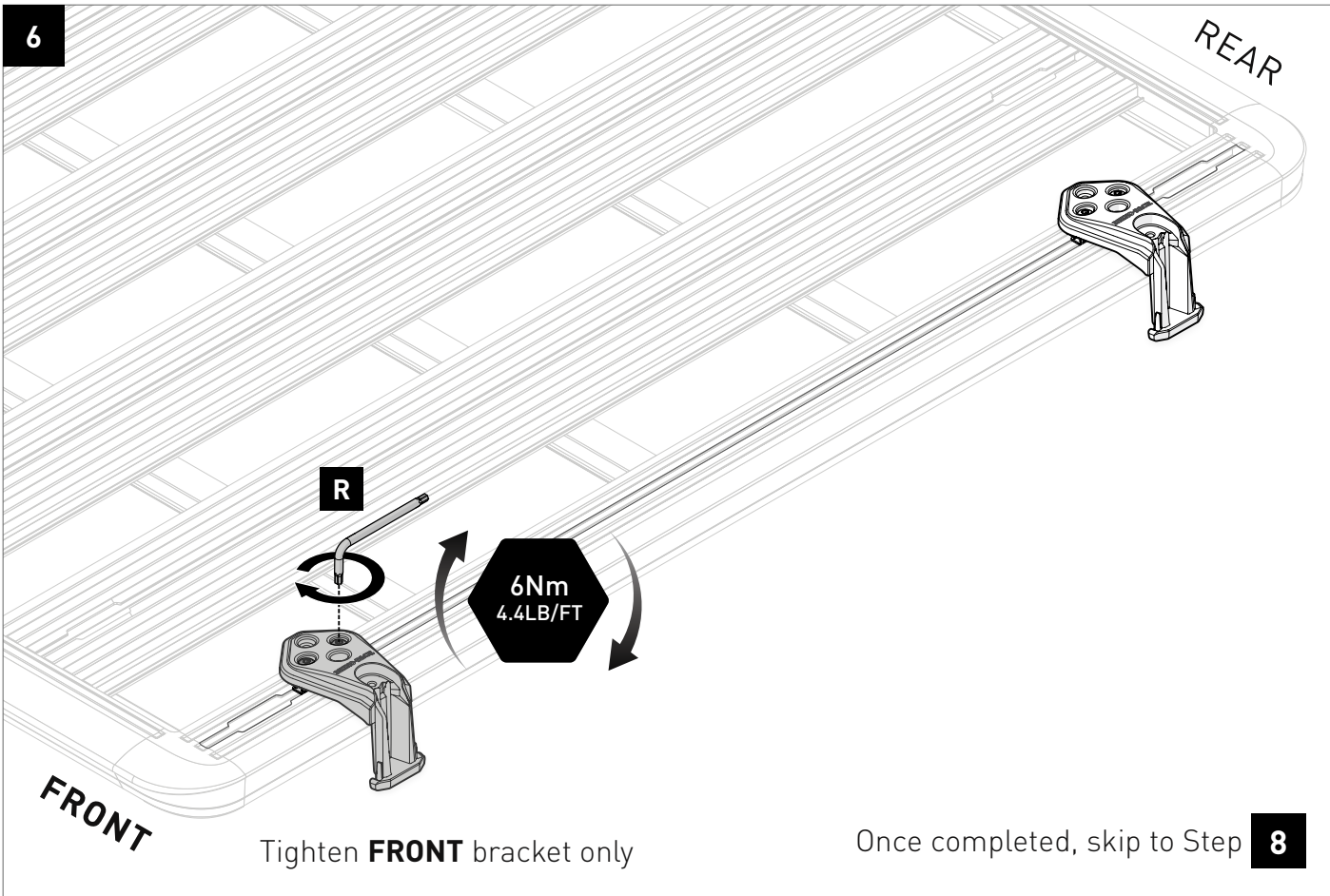

FOR INSTALLATION ONTO CROSSBARS

(For Platforms / Reconn-deck NS Bars skip to Step **8**)

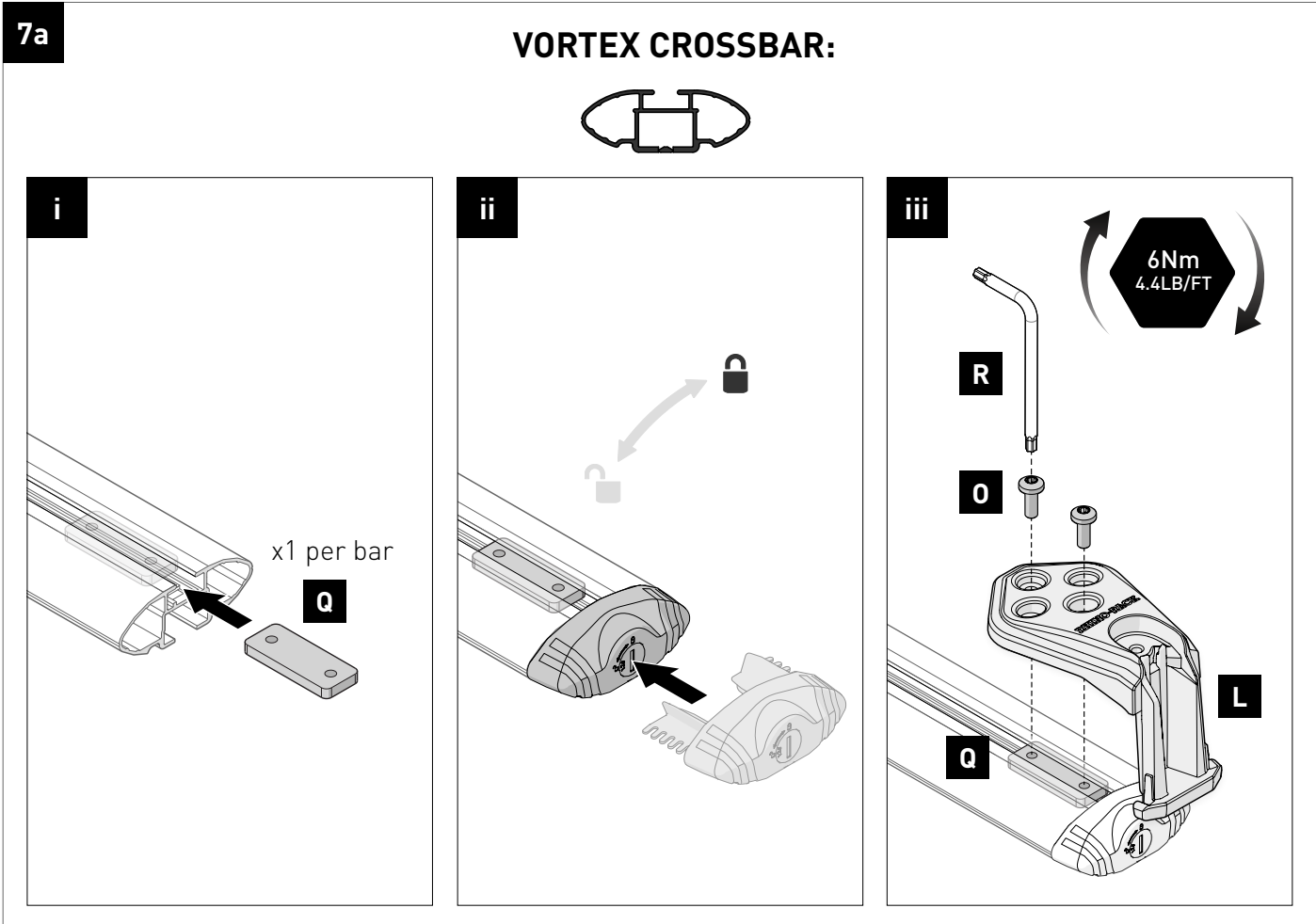

7b

HEAVY DUTY CROSSBAR:



i

LOOSELY ASSEMBLE

*Requires **B120027-BP**
(SOLD SEPARATELY)

x2

*Requires **N002-BP**
(SOLD SEPARATELY)

ii

6Nm
4.4LB/FT

R

SIDE VIEW

7c

RECONN-DECK CROSSBAR: Continues to next page.



i

LOOSELY ASSEMBLE

O

L

P

x2

P **P**

40 **35** **35** **40**

P **P**

40 **35** **35** **40**

7c

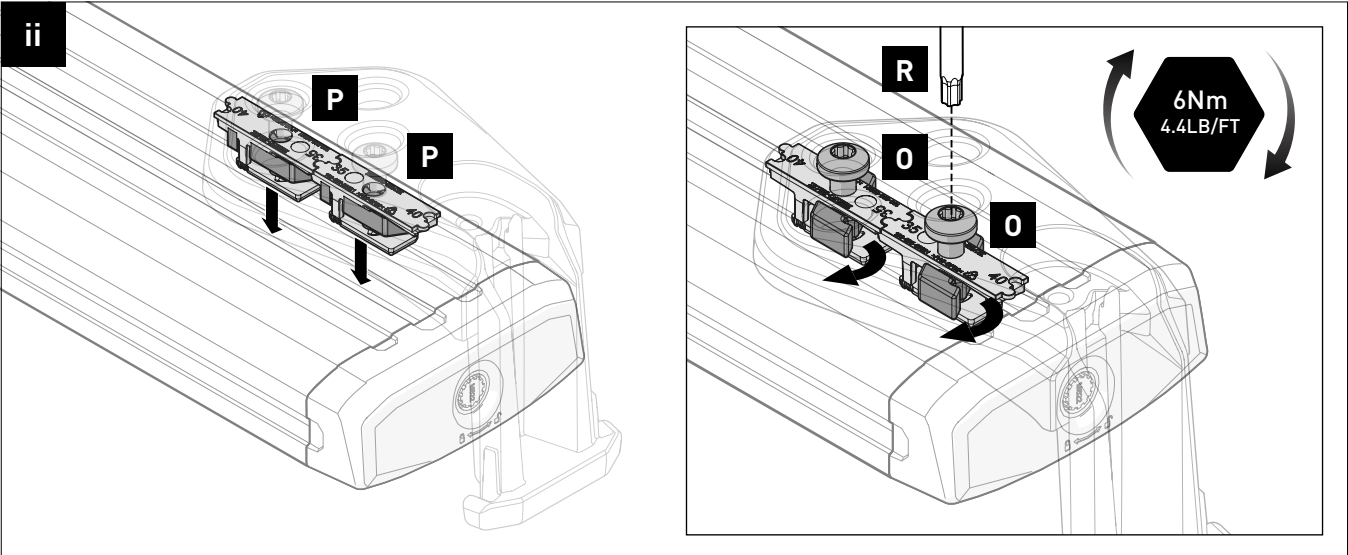

8 Install the Pick Up Moulding at the REAR OPPOSITE SIDE of the vehicle to the Batwing Awning and tighten in place.

Assemble:

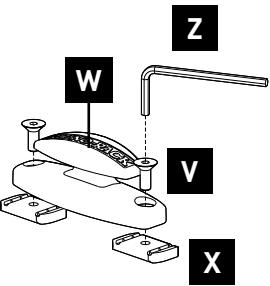

CROSSBARS:

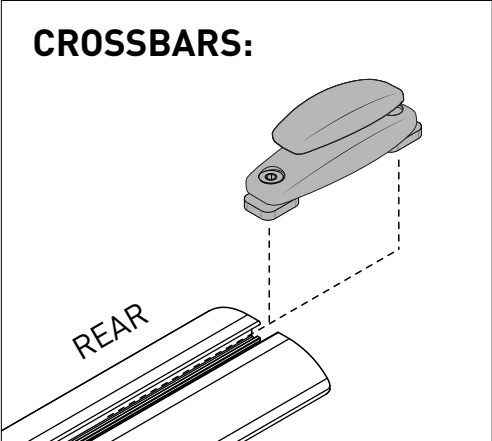

PLATFORM:

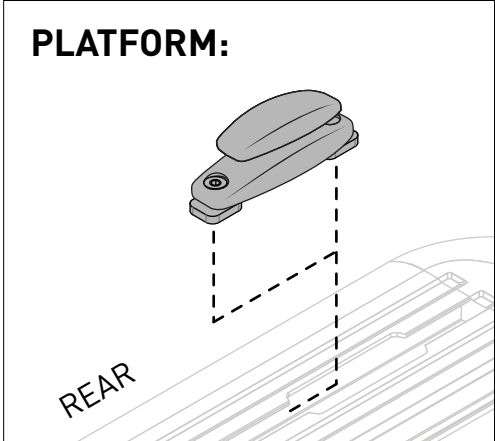

9

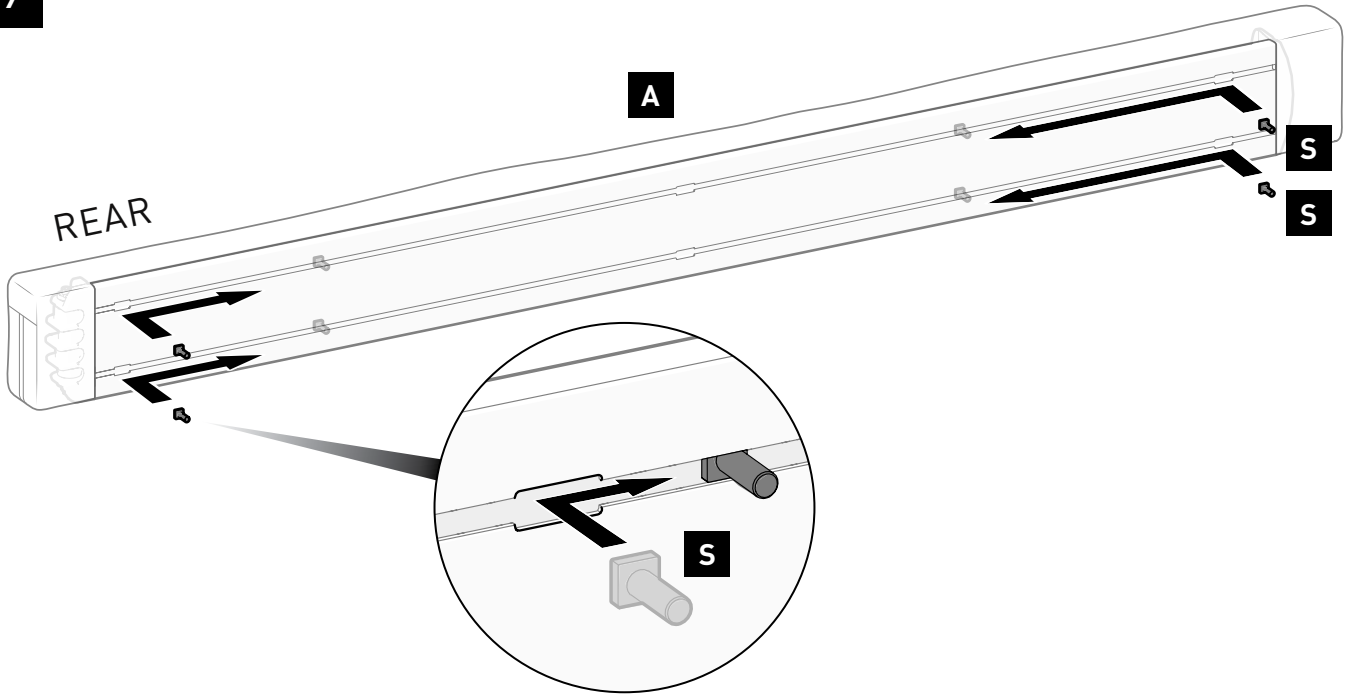

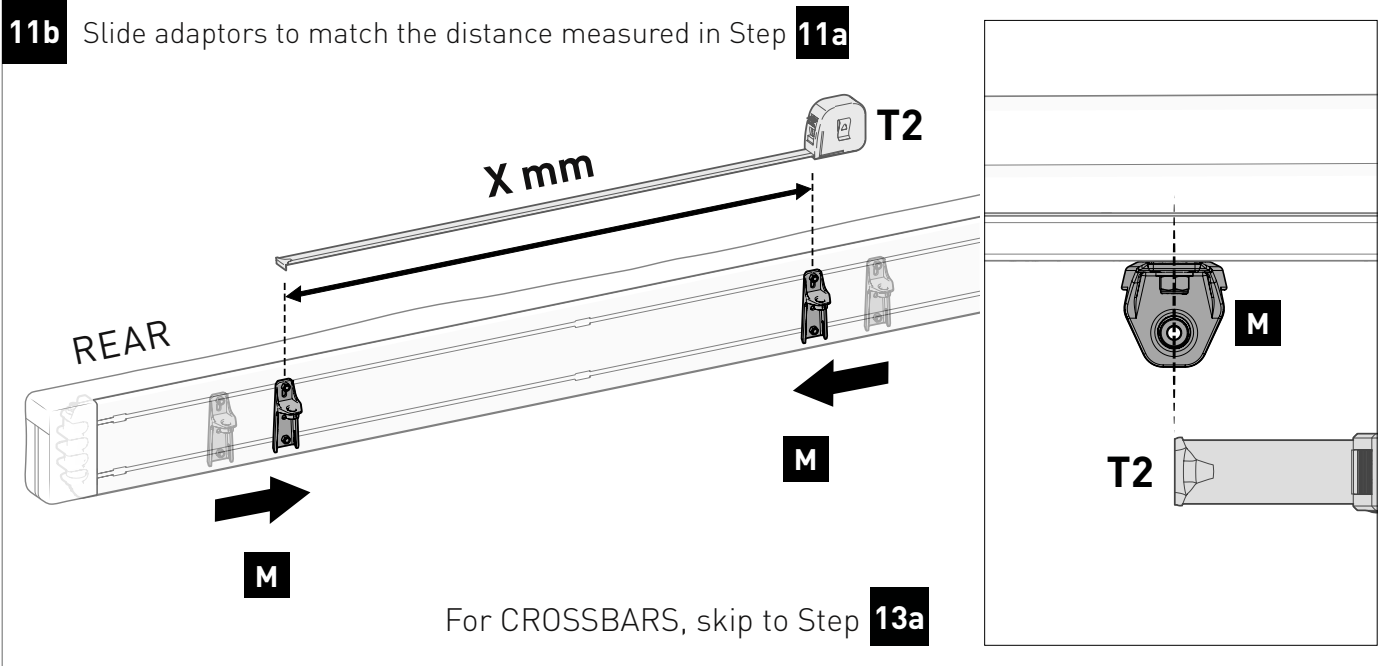
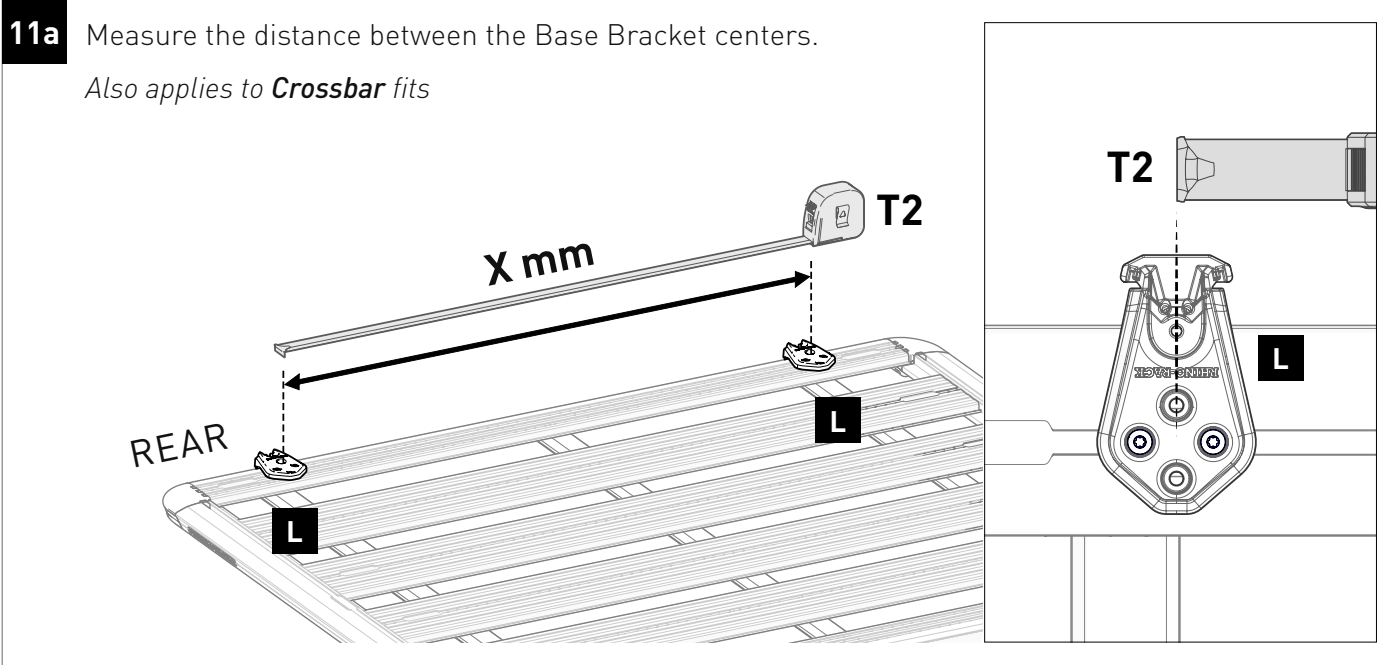
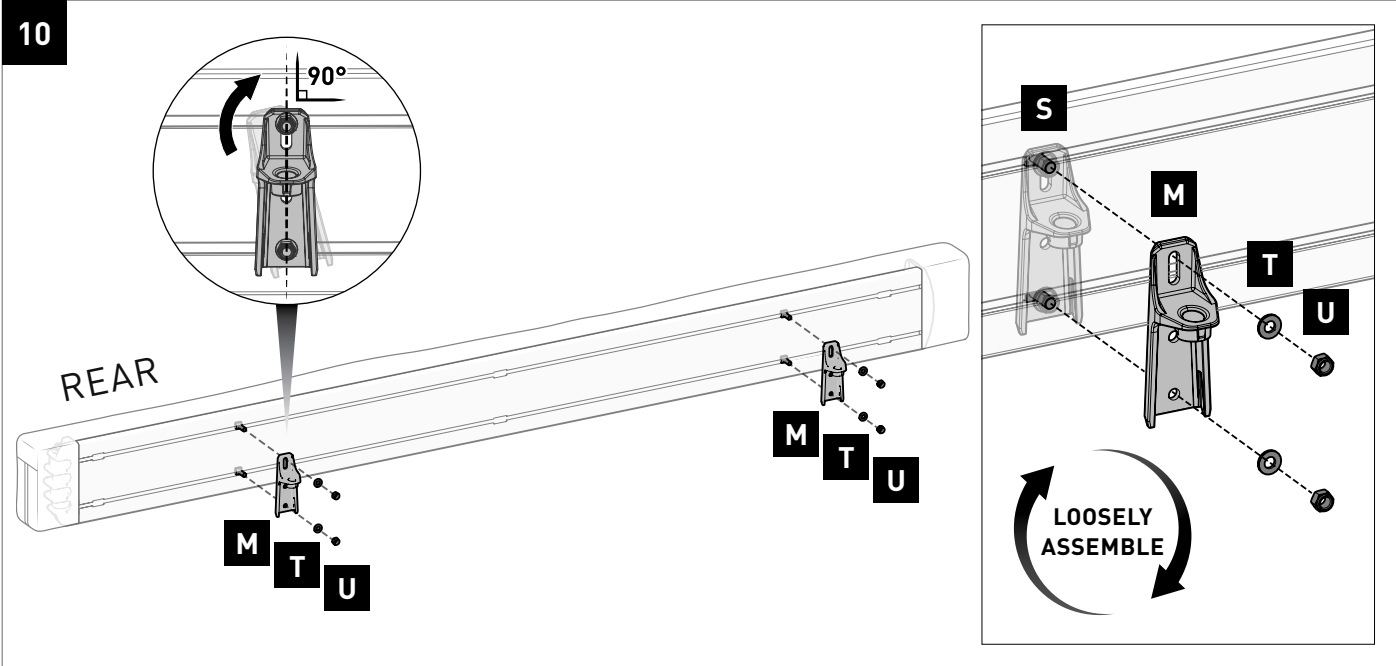

12

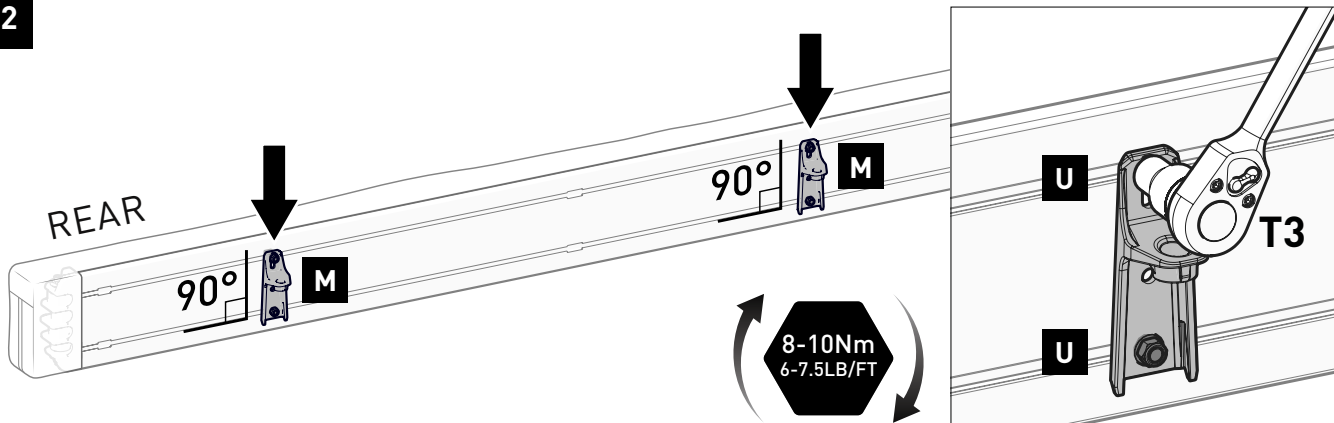

13a Place Batwing with Adaptors onto Base Brackets.

FOR CROSSBARS: Complete Step 13a and then skip to Step 17

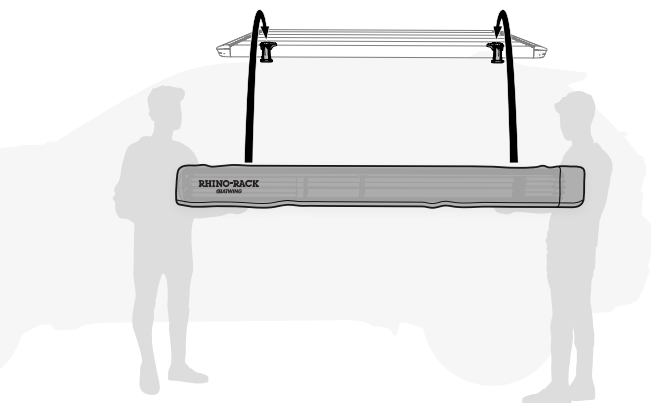

T4



NOTE: Step Ladder may be required for taller vehicles

13b

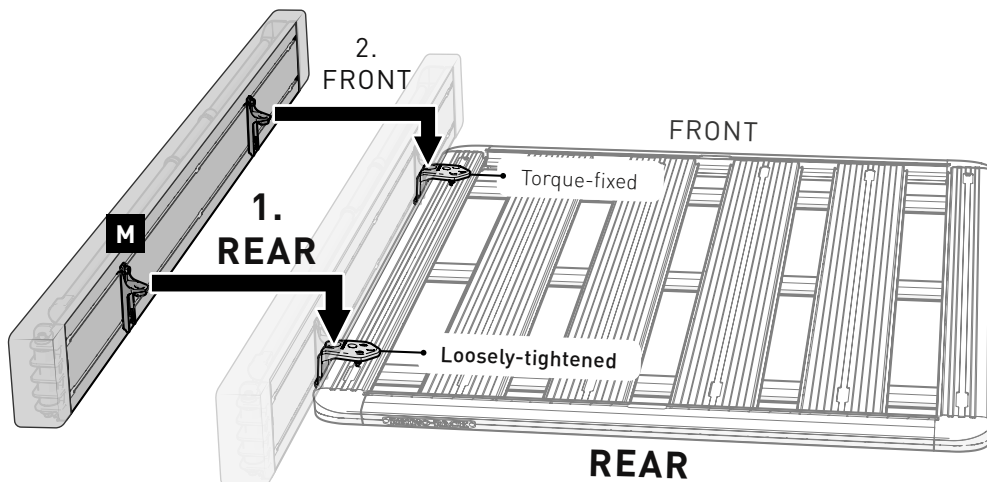

IMPORTANT: Inspect both connections overhead before releasing awning.

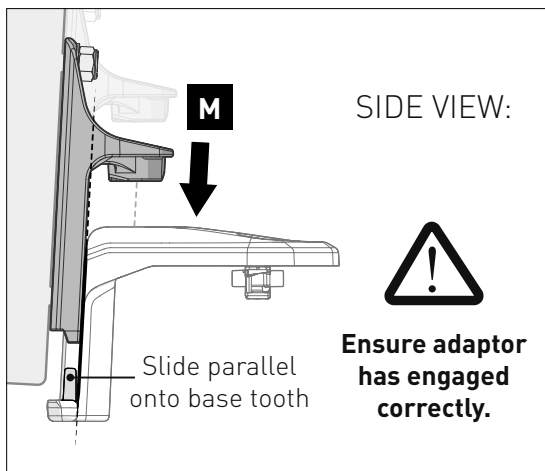
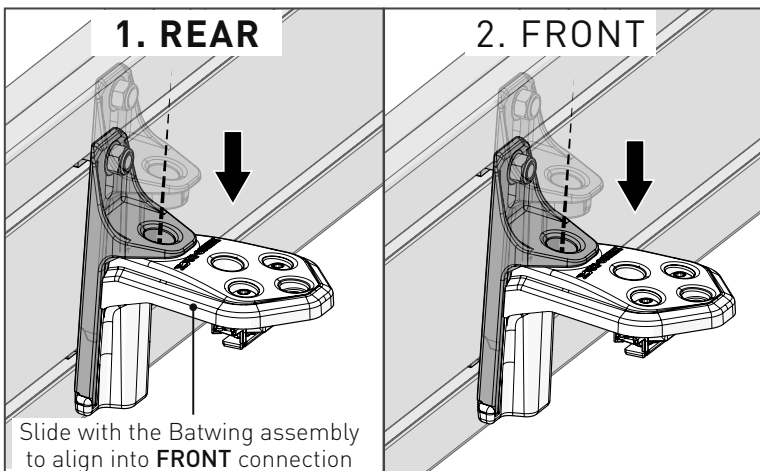

SIDE VIEW:

Ensure adaptor has engaged correctly.

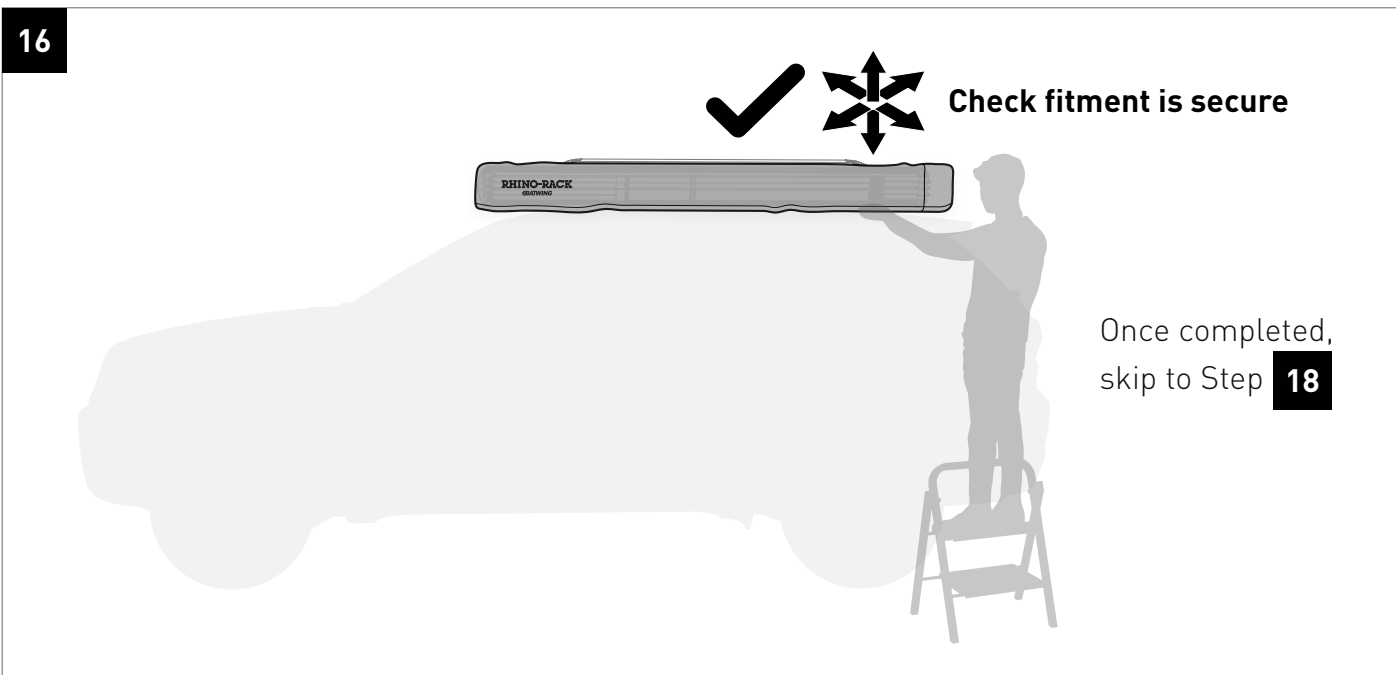
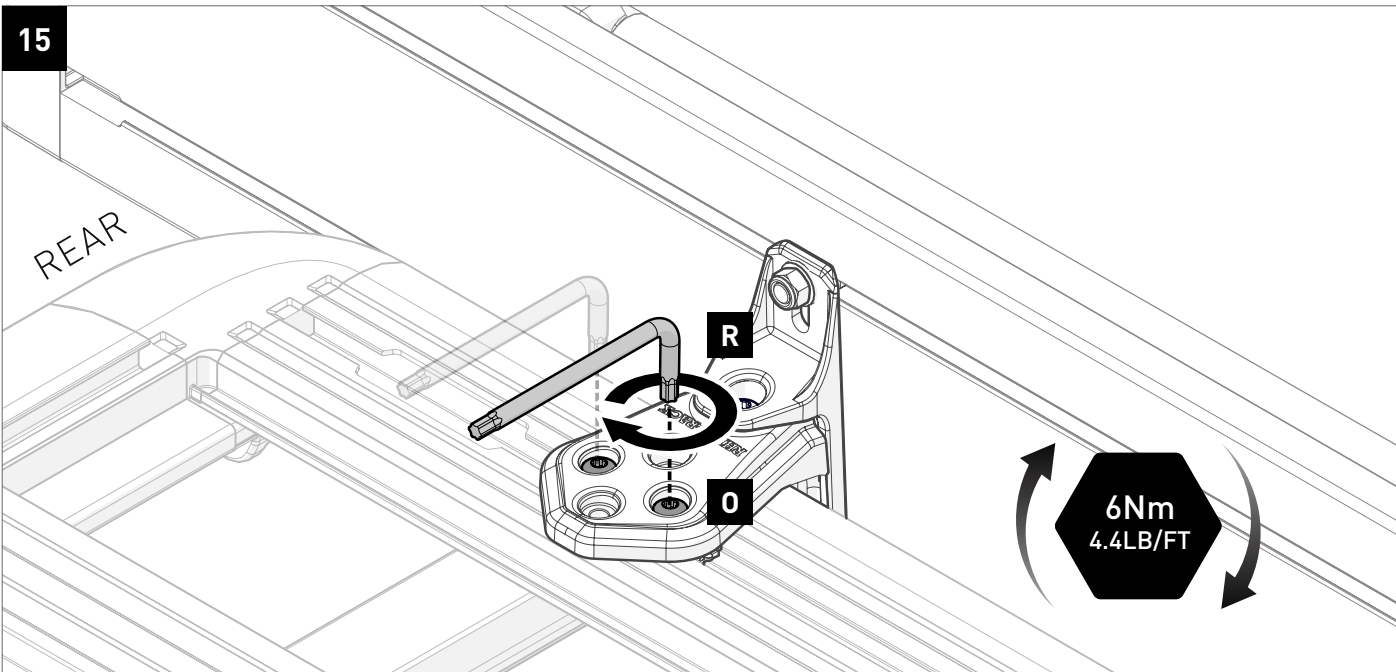
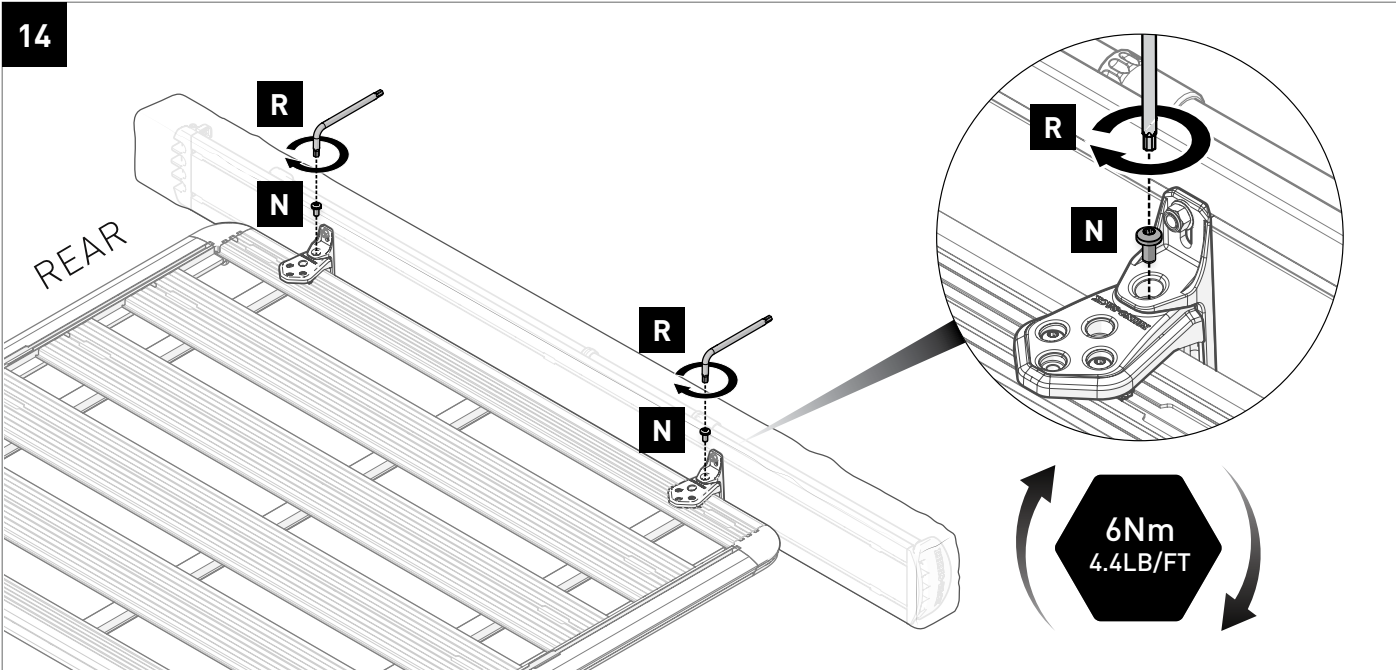

FOR CROSSBARS ONLY

(For Platforms / Reconn-deck NS Bars skip to Step **18**)

17

- 17a** Position Batwing to below dimensions.
NOTE: Be aware of tail gate position and adjust awning accordingly.

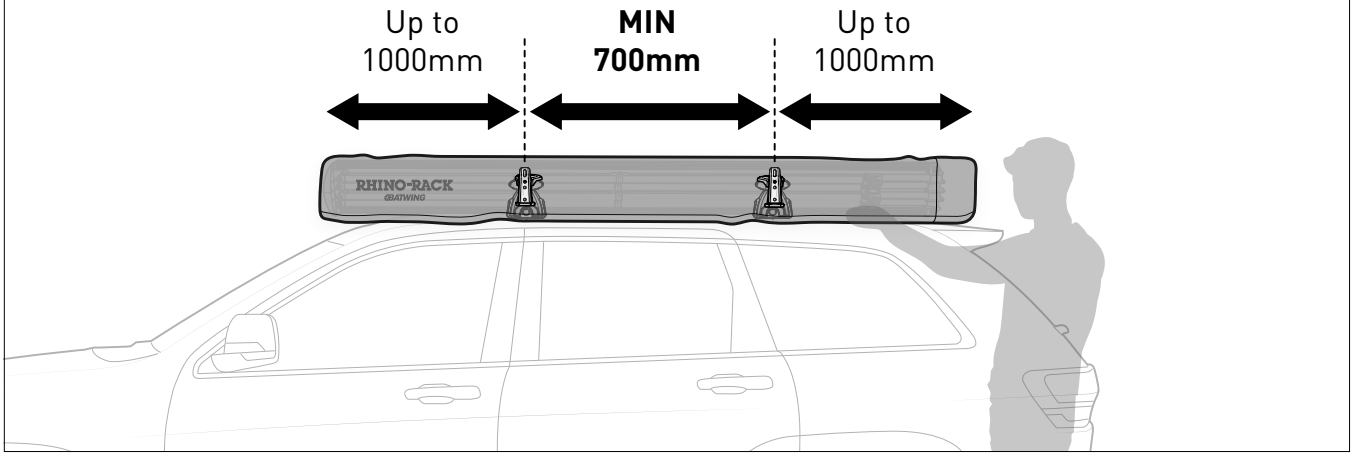

- 17b** Remove Batwing



Ensure Adaptors do not shift position when lifting Batwing off Base Brackets

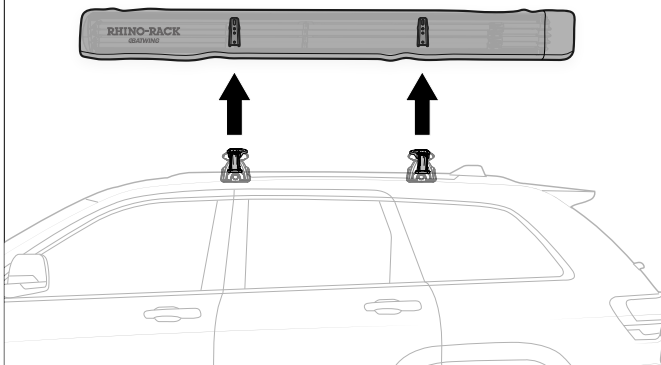

- 17c** Tighten hardware on both Adaptors.

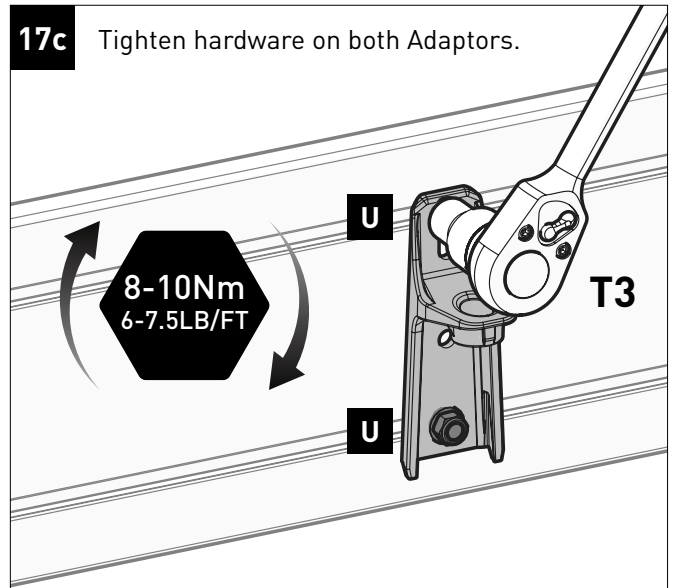

- 17d** Reattach Batwing

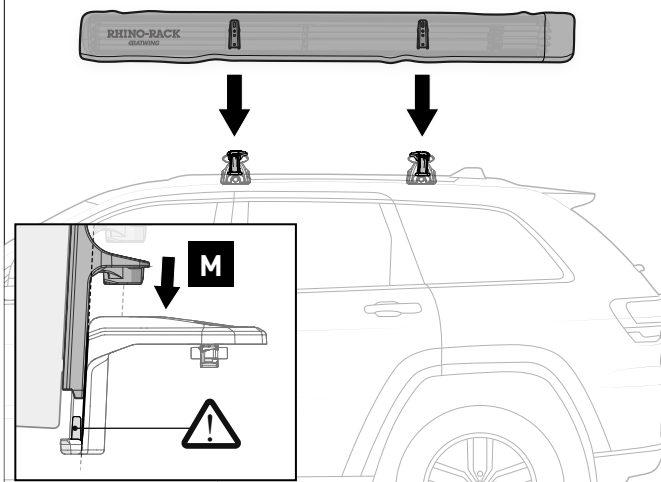

- 17e** Install to both Brackets

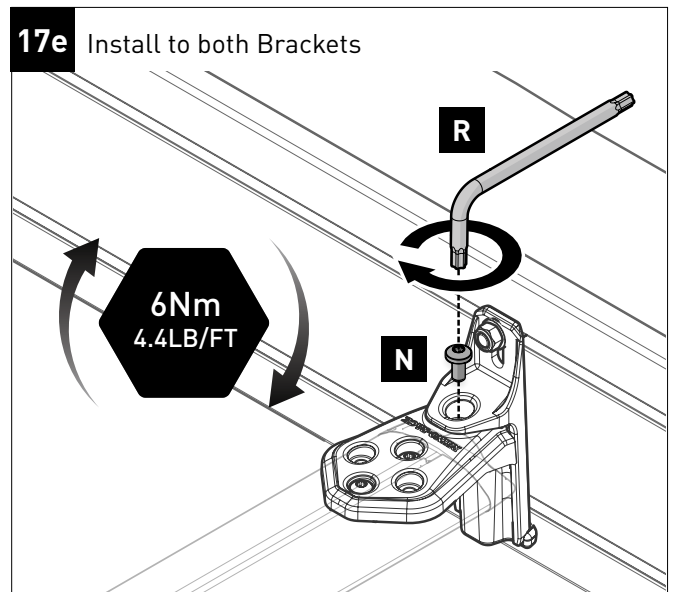

BATWING OPERATION

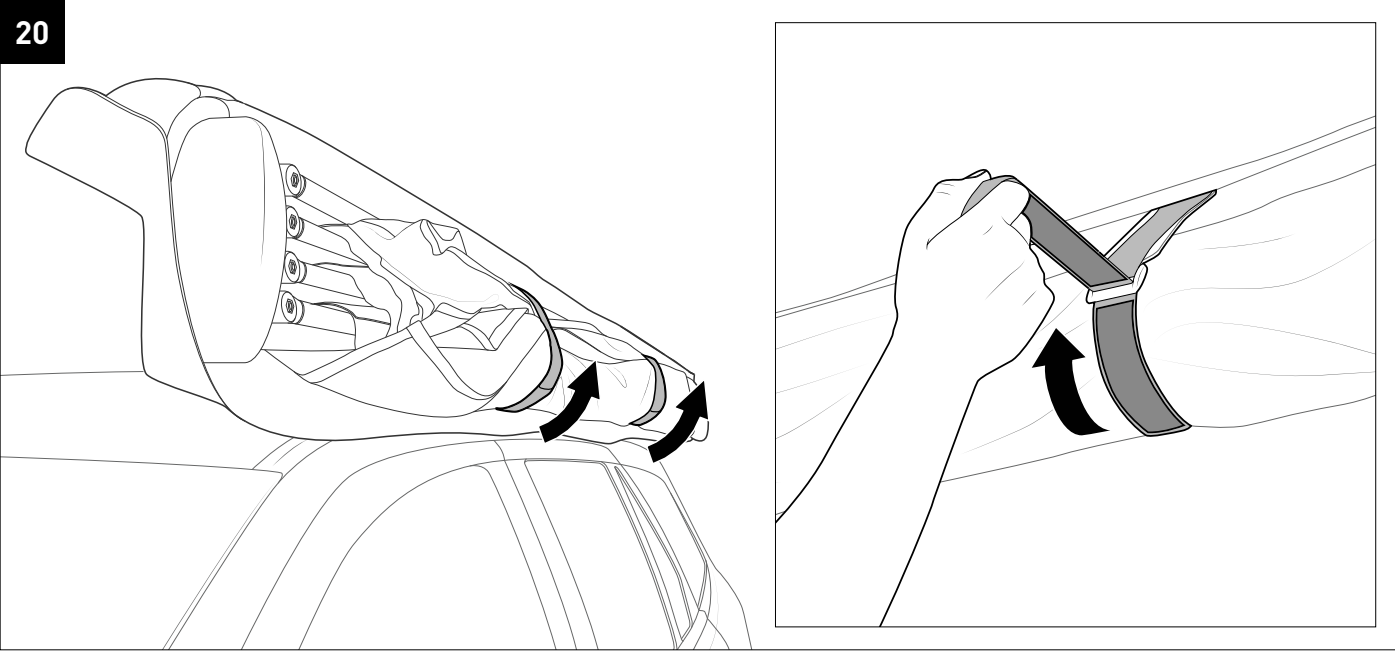
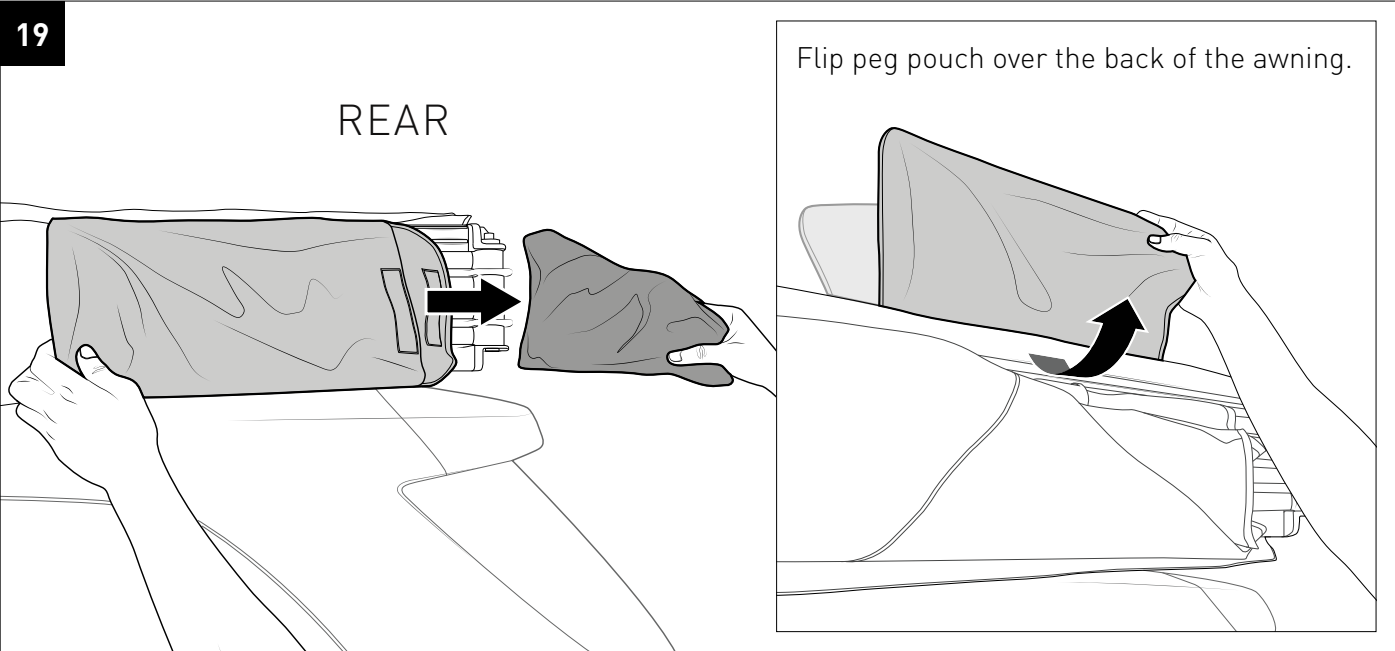
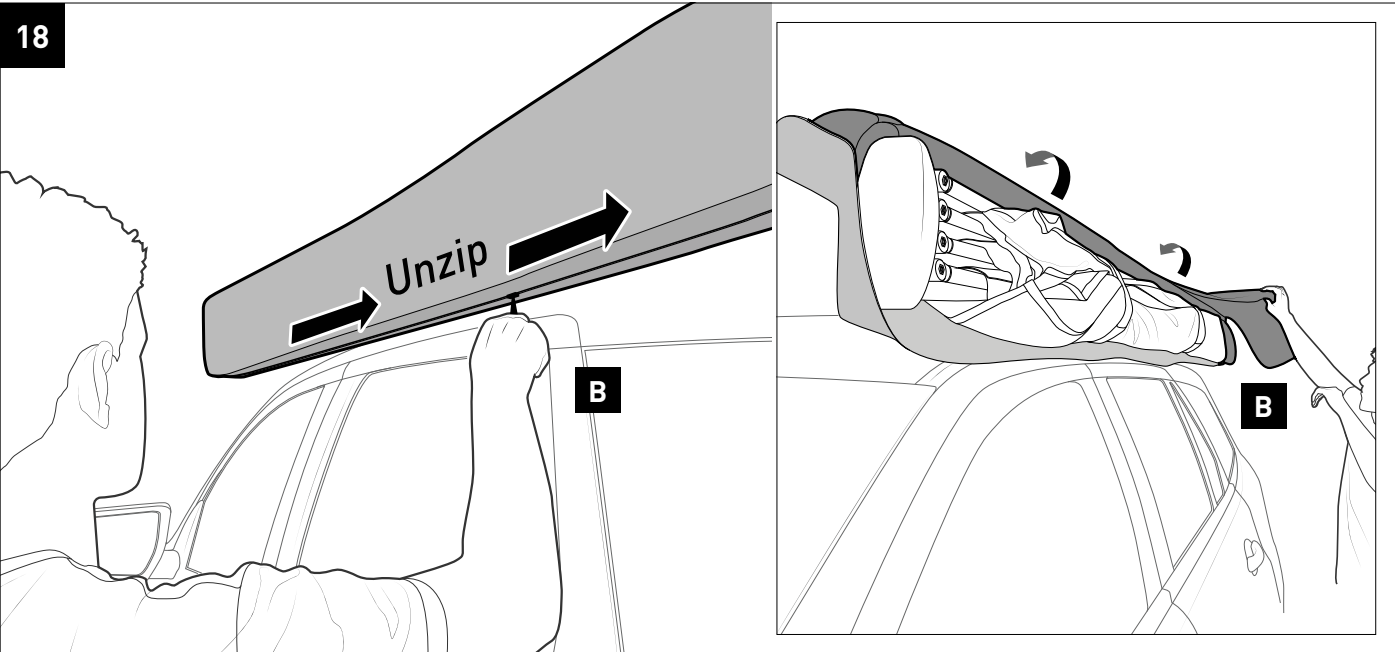

21

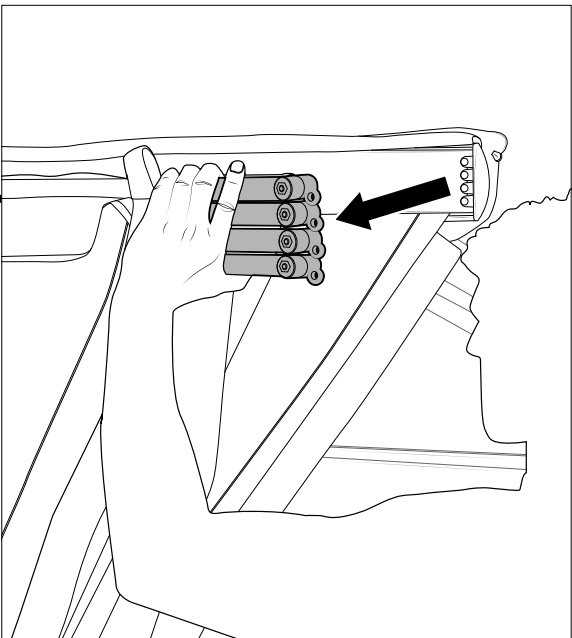
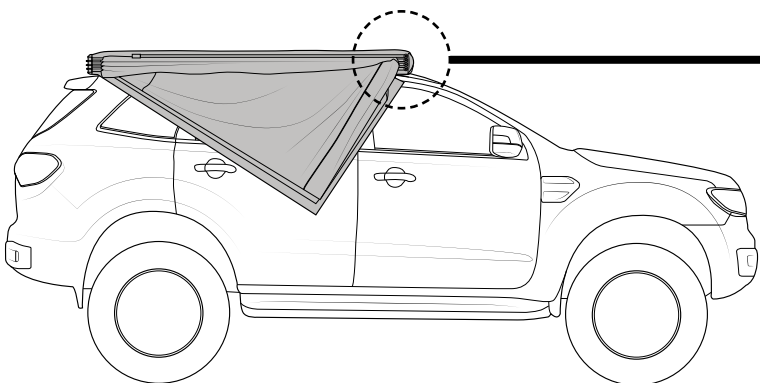

22a Open the **first** Awning wing, and lower pole to the ground.



TWO PEOPLE
REQUIRED

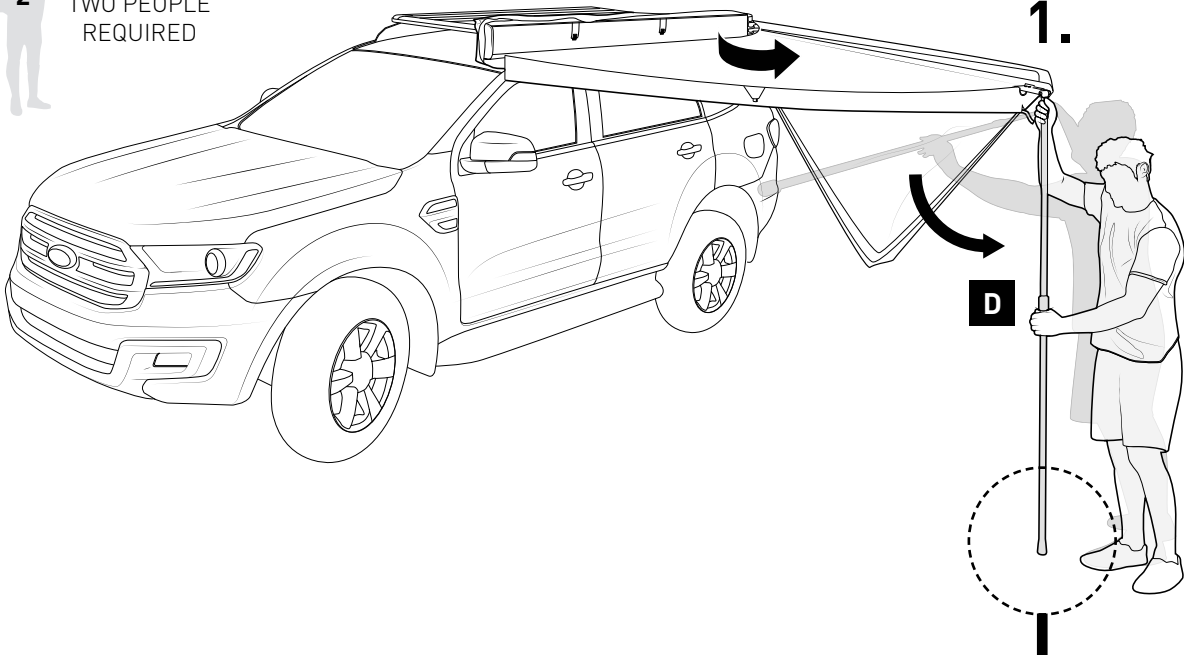

With the help of a second person,
drive pegs through the foot of the
support.

NOTE: Leave a small gap to allow
pegs to be removed easily.

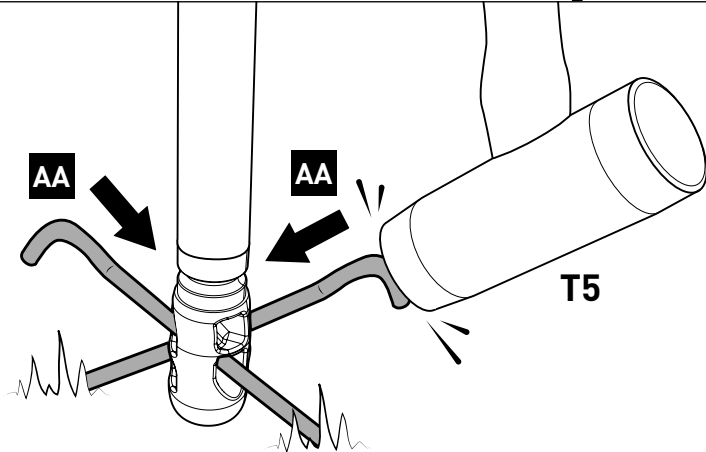

22b Repeat the above process for **Pole 2** and **Pole 3**, then refer to Step **22c**

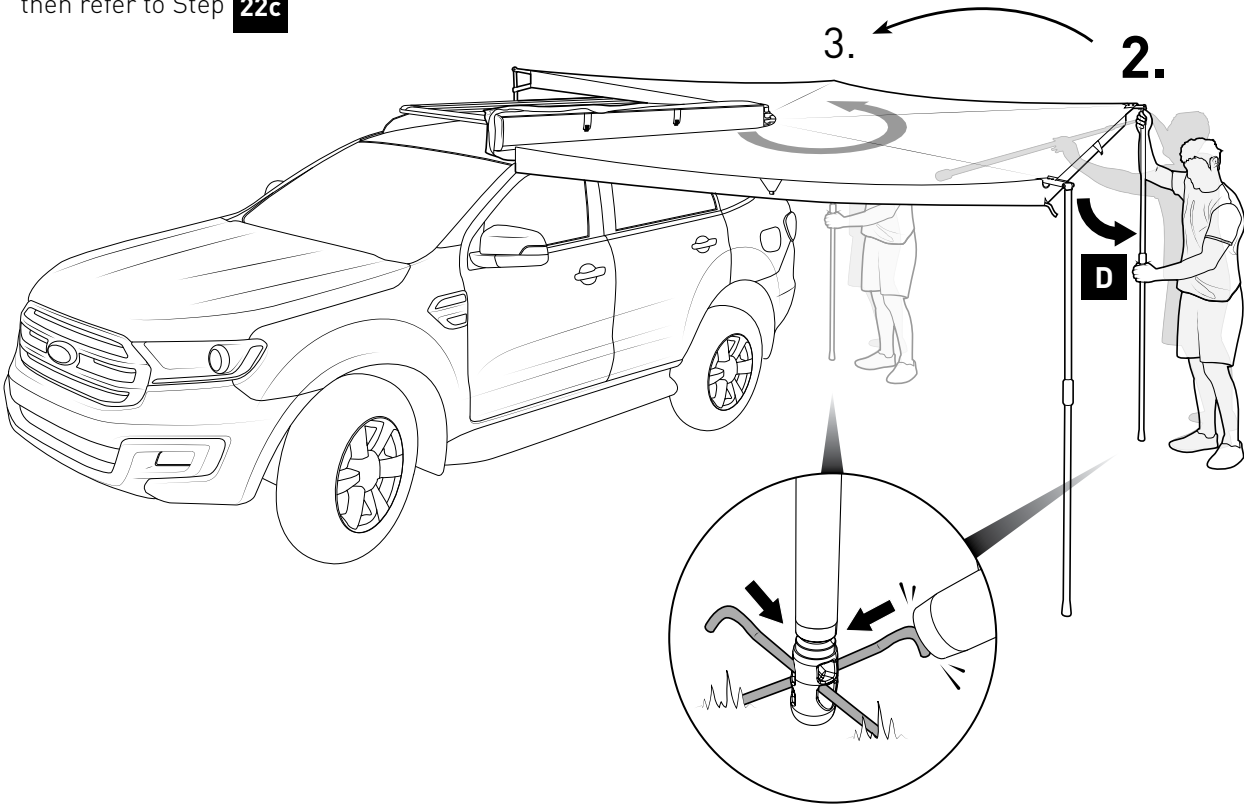

22c Repeat the above process for **Pole 4** and **secure all retention straps**.

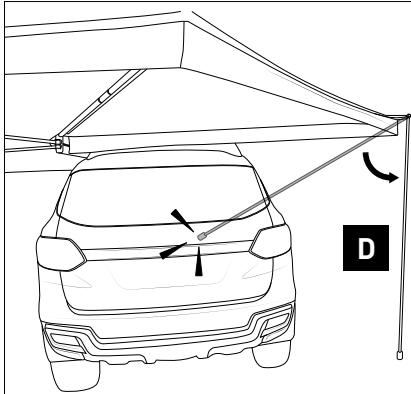
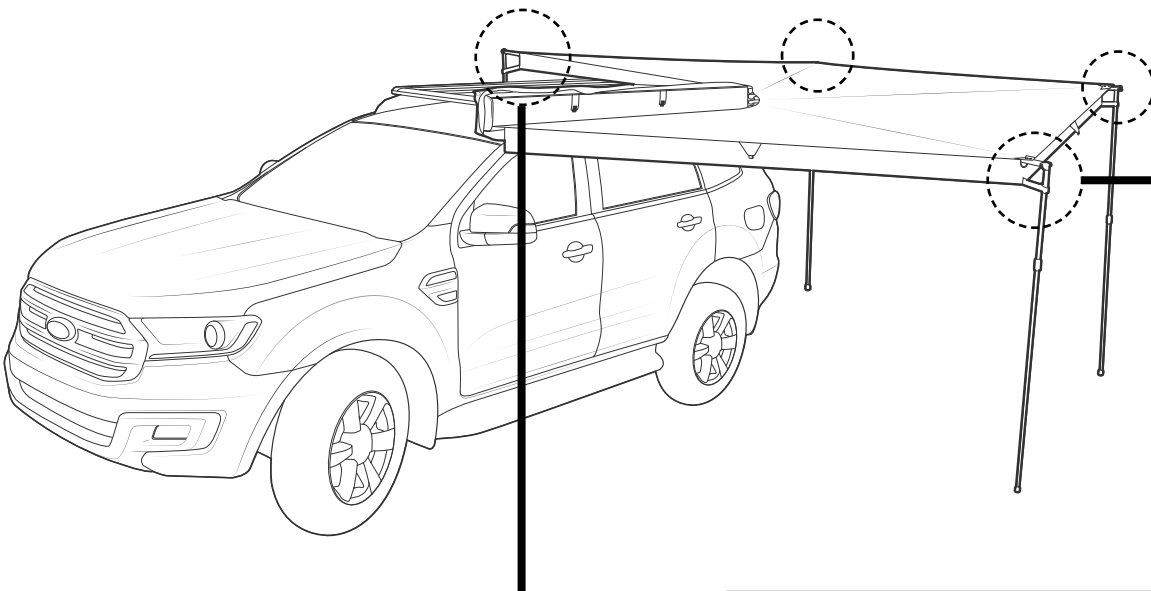

Ensure 4th support clears the REAR of the vehicle when dropped down.

NOTE: Momentarily undo retention strap when lowering pole if necessary.

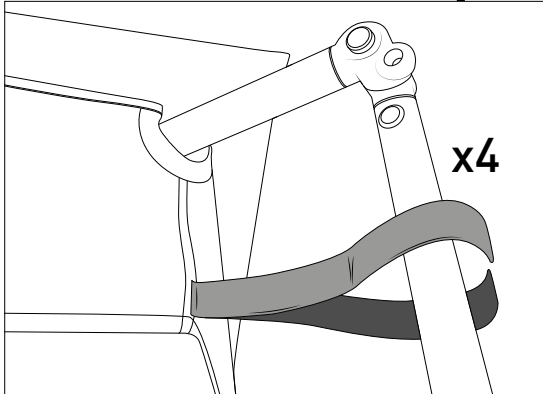

23

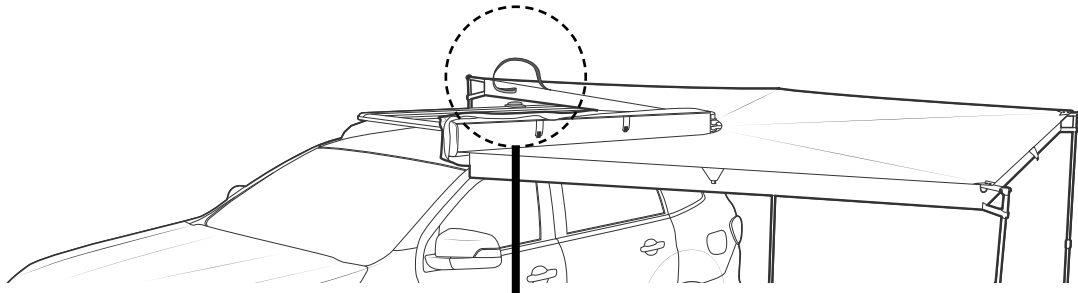

23a

NOTE:

End horizontal support may have a slight curve after tensioning. This is normal on some vehicles.

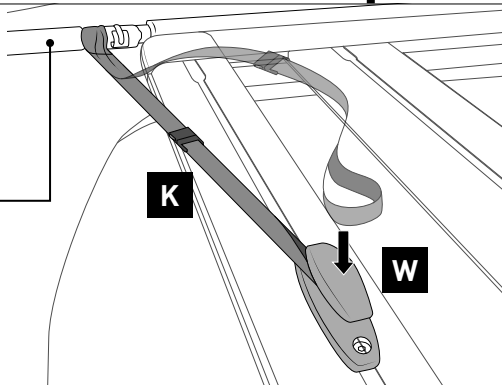

23b

Tension strap as required.

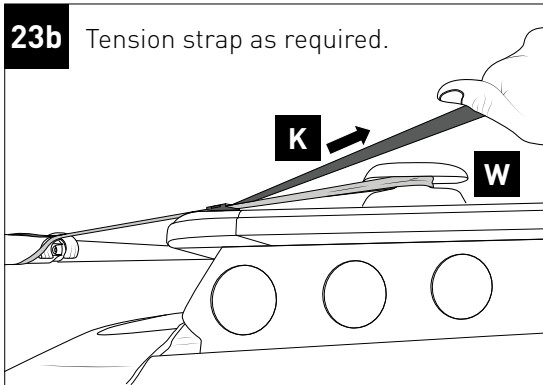

24

Tighten the support poles in place at the selected height.

NOTE: Once these heights are set for your vehicle, they can be left at this length even when stowed away.

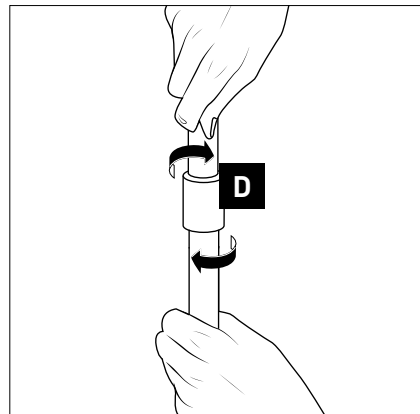
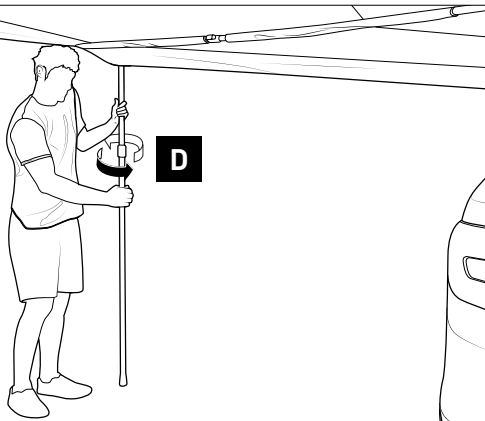

25

Drive the metal pegs into suitable ground on the outside of the supports. Hook the ropes to the awning, fixing it in place as shown.

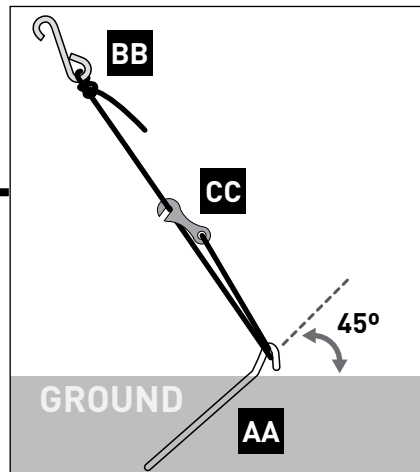
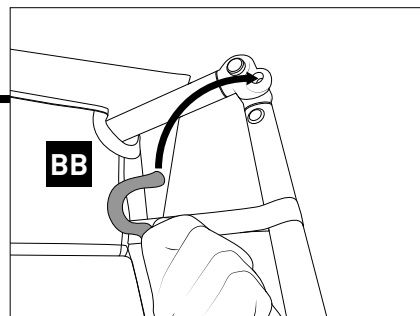
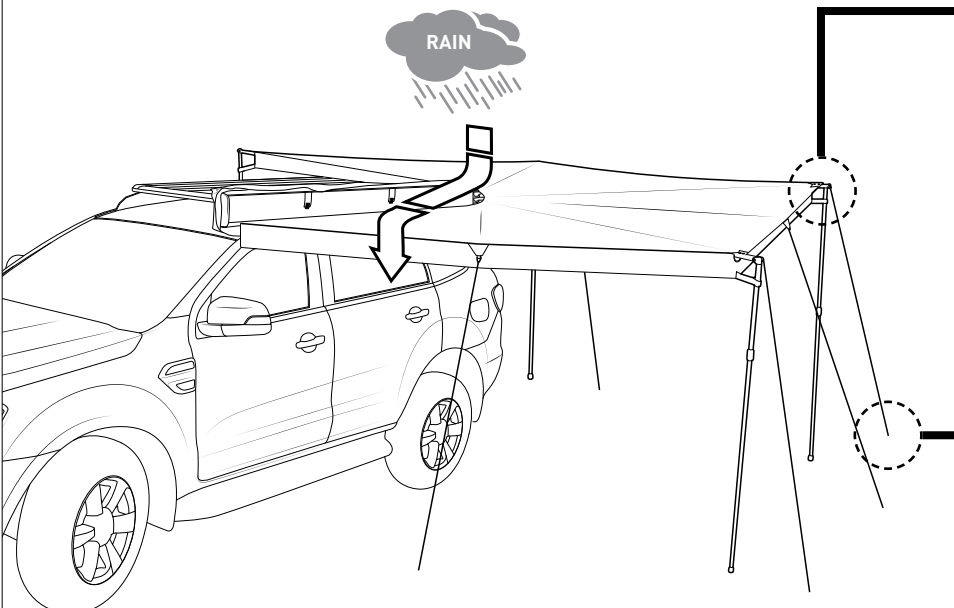

NOTE: When raining, lower poles and tension guy rope to help rain flow off awning freely.

STOWAGE INSTRUCTIONS

(Completion of Steps 18 - 25 in REVERSE order. Use below steps for reference)

26 Undo tension strap and all guy ropes.

Unclip the strap if required, then re-attach to ensure it is not lost.

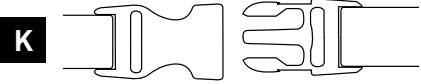
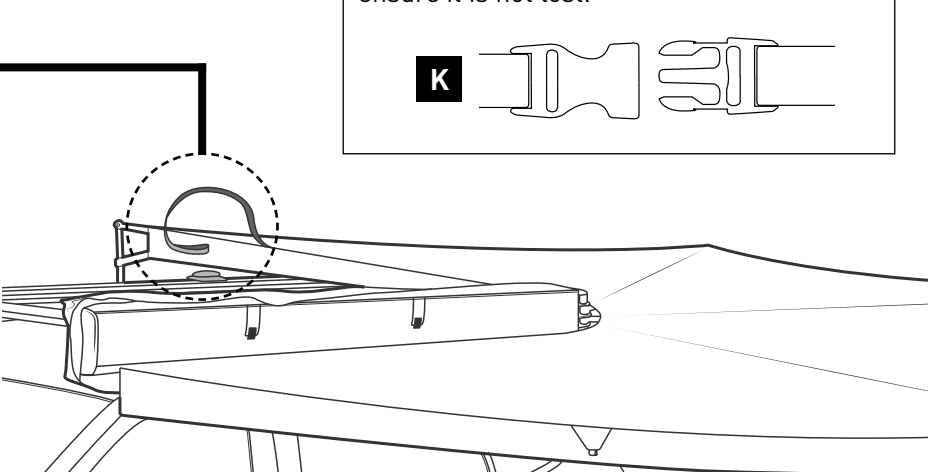
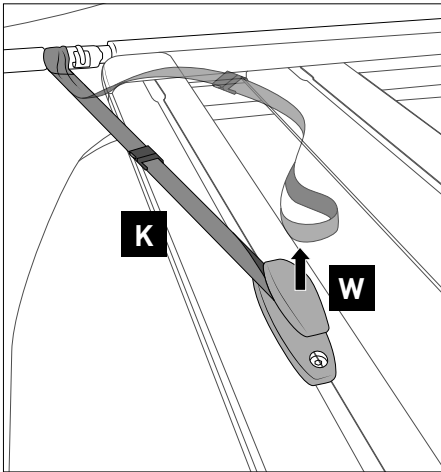
27a Swing each arm back towards the body of the awning. Stack each arm 1 - 4 on top of the one before it as shown in **27b**

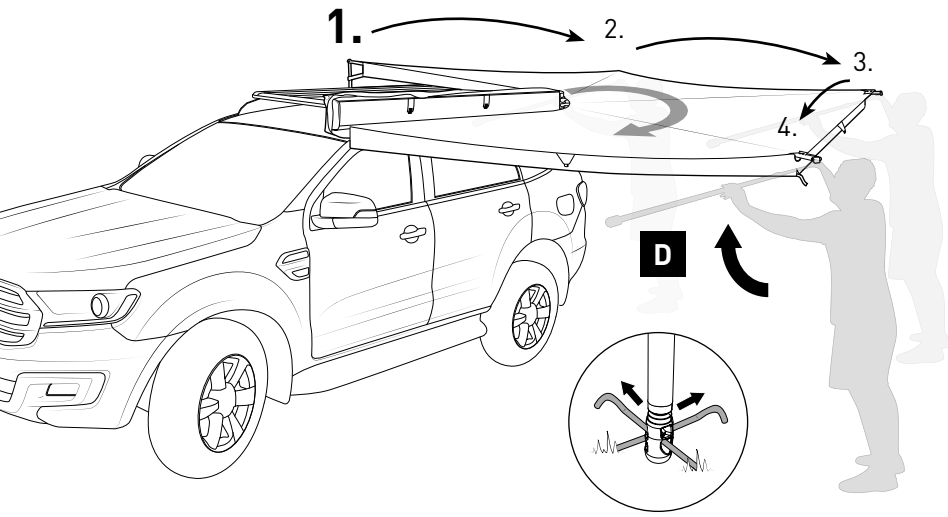
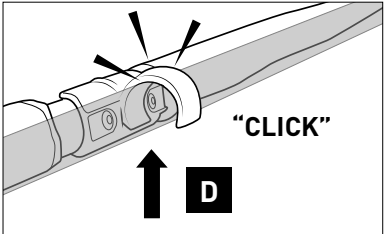
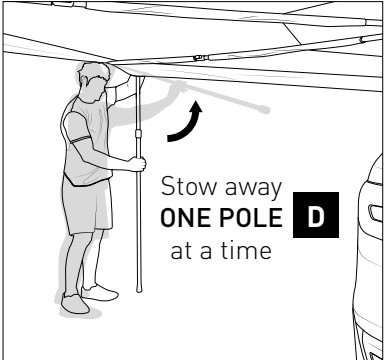

27b Place all 4 arms back onto the magnets **C** at the same time.

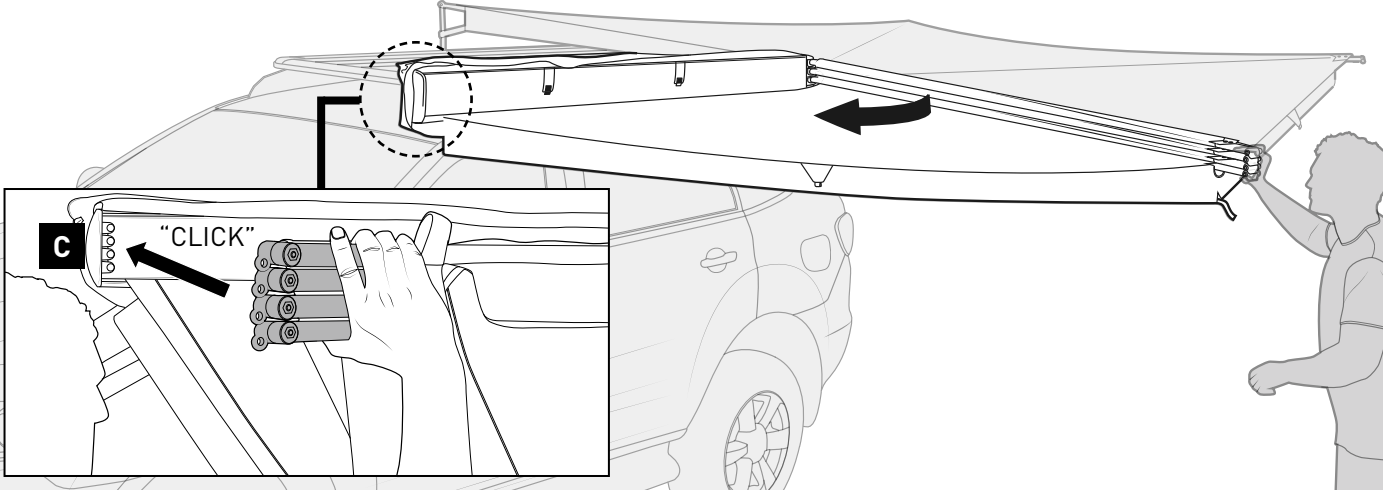

28

28a Fold the awning material in half.

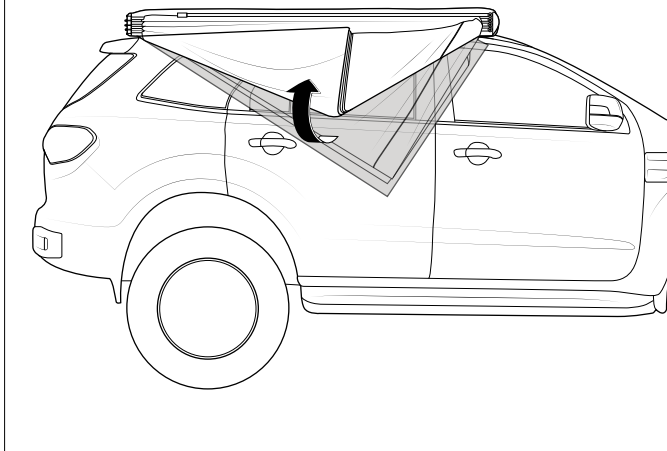

28b Roll the material from the front edge back up into its original setting.

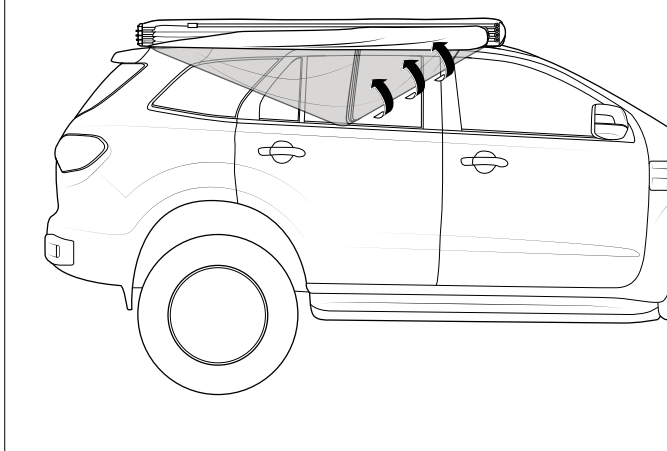

28c

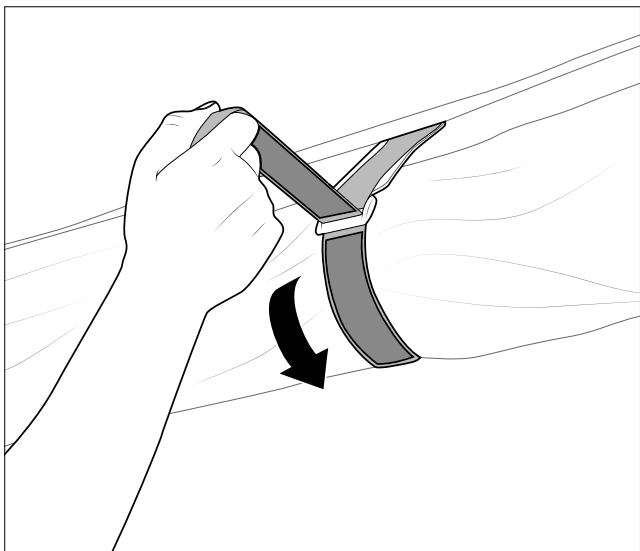
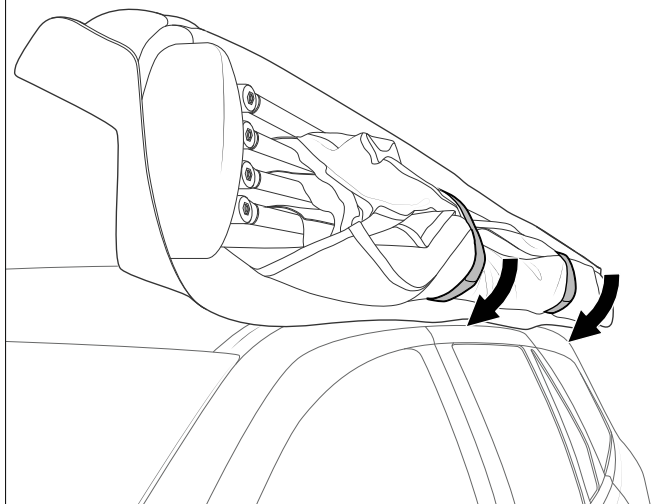

29 Replace the metal pegs and guy ropes to their original position. Zip the outer bag closed.

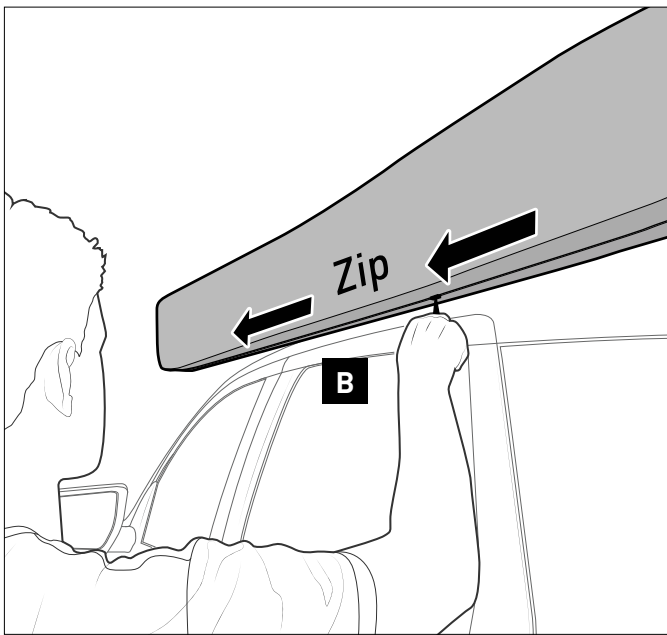
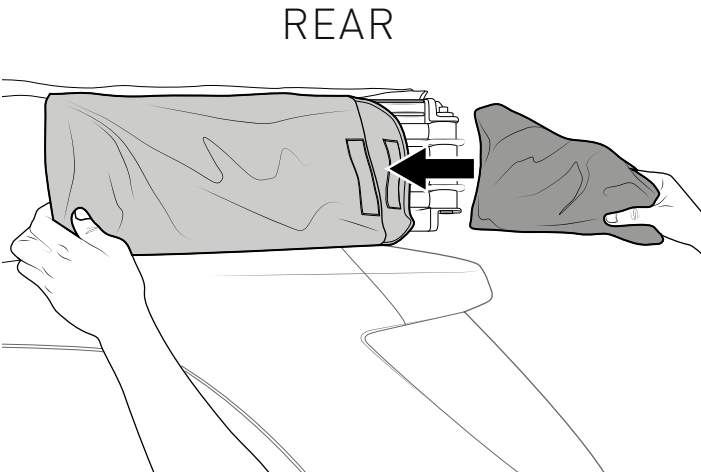

MAINTENANCE & REPAIR

SUPPORT ARM ADJUSTMENT:

The support arms are designed to allow slight adjustment by the end user. When housed, if the arms are not sitting flush with end cap **Fig. A**, adjust the rotation on the arm using **T6** Phillips Head Screwdriver.

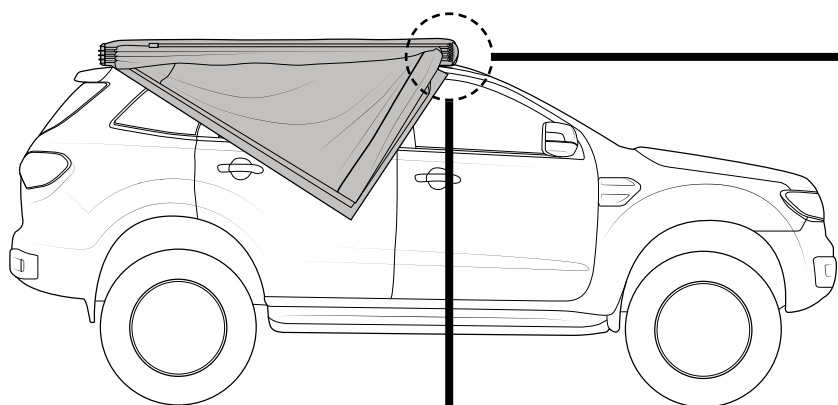

Fig. A: If the arm is off centre, the magnet in the end cap will not secure the arm in place properly.

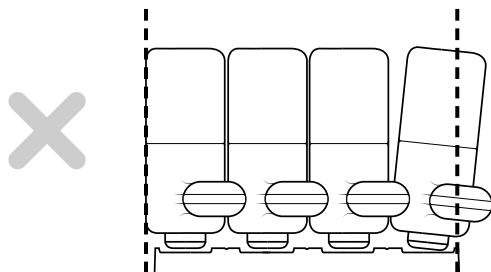
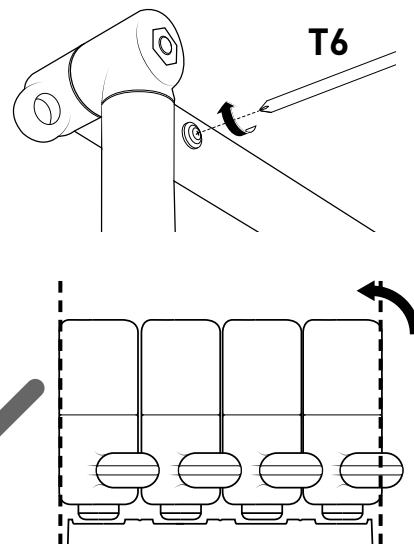
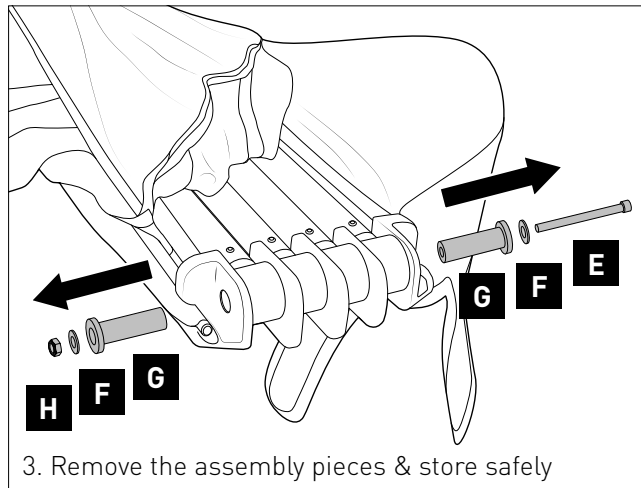
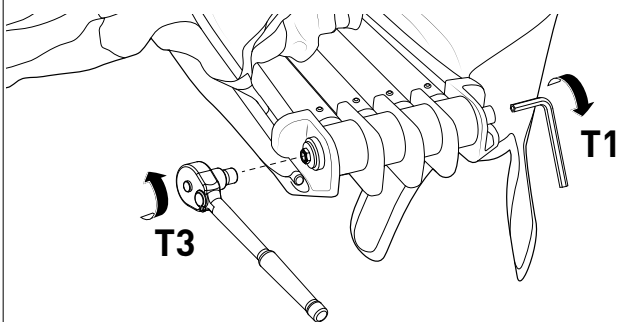

Fig. B: Loosen the screw behind the drop down hinge, adjust the arm rotation and re-tighten the screw.



SPAR HINGE REPAIR:

1. Remove awning from vehicle.
2. Use **T3** 13mm Socket Wrench and **T1** 6mm Allen Key to undo the casting assembly.



4. Using **T6** Phillips Head Screwdriver, remove the screw holding the damaged hinge moulding in place.
5. Replace with the spare hinge provided.

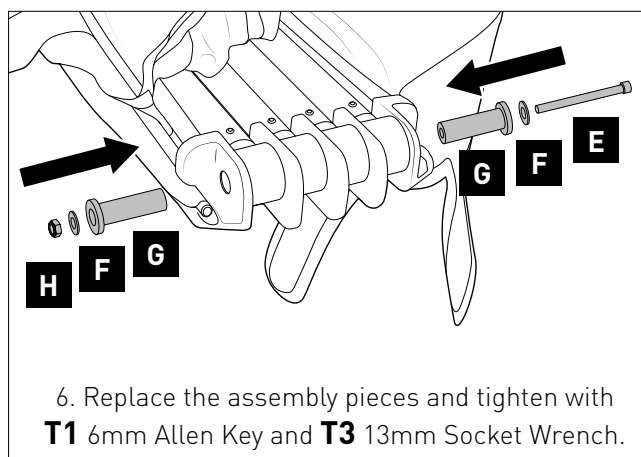
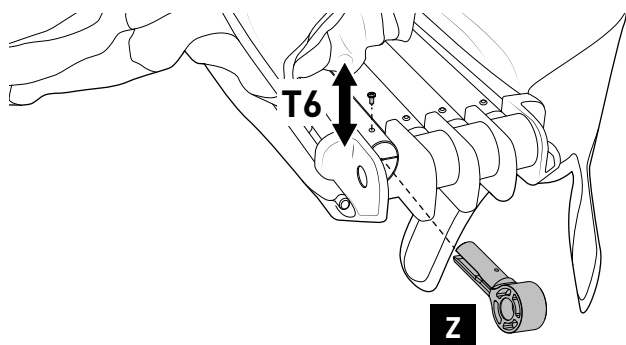

BAG REPLACEMENT:

REMOVAL OF PREVIOUS PVC BAG:

1. Unzip the bag and remove the velcro straps.

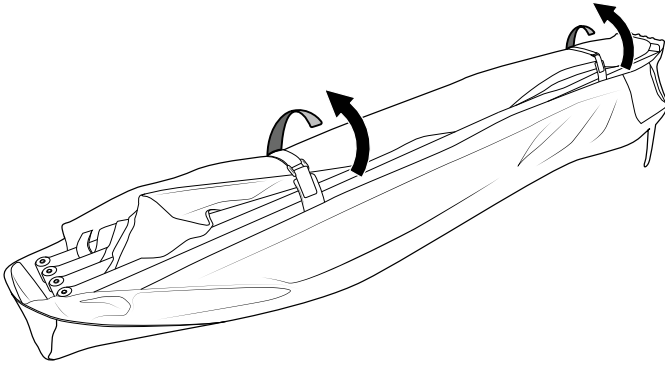

2. Peel bag off the Batwing ends, taking extra care around corners.

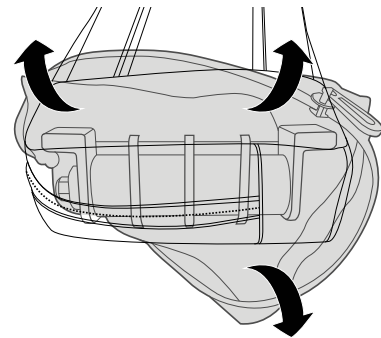

3. Carefully slide bag off.

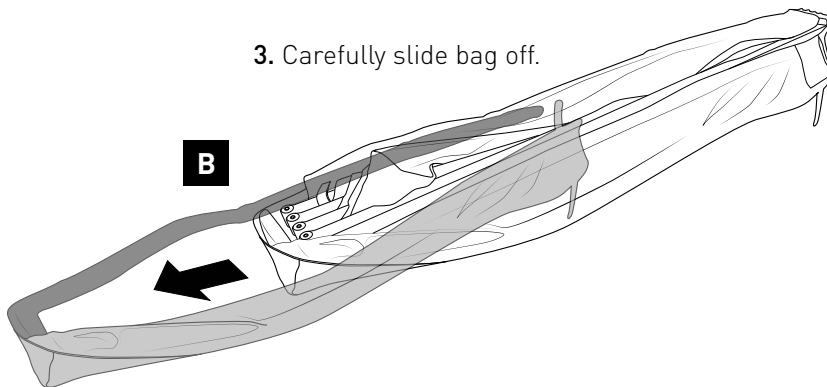

REPLACEMENT:



Be sure **correct orientation** is used.
The **matte finish of the PVC bag faces the outside.**

4. Slide new bag into the tracks.

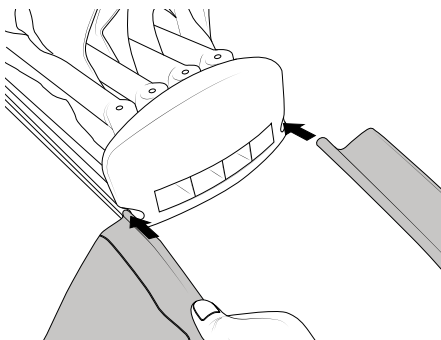

5. Carefully slide bag on.

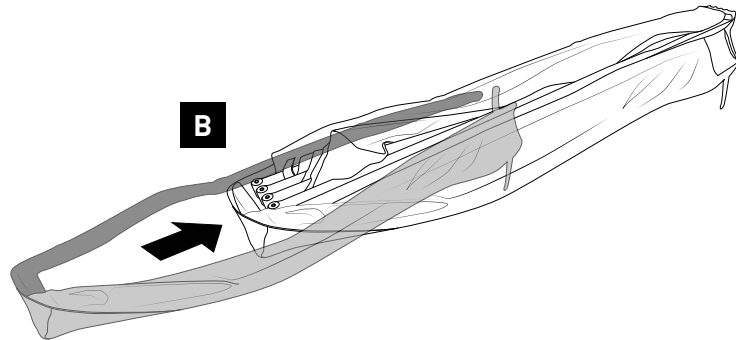

6. Fold bag over the Batwing ends, taking extra care around corners.

